



US007988984B2

(12) **United States Patent**
Hockaday

(10) **Patent No.:** **US 7,988,984 B2**
(45) **Date of Patent:** **Aug. 2, 2011**

(54) **INSECT REPELLENT AND ATTRACTANT AND AUTO-THERMOSTATIC MEMBRANE VAPOR CONTROL DELIVERY SYSTEM**

(75) Inventor: **Robert G. Hockaday**, Los Alamos, NM (US)

(73) Assignee: **Energy Related Devices, Inc.**, Los Alamos, NM (US)

(*) Notice: Subject to any disclaimer, the term of this patent is extended or adjusted under 35 U.S.C. 154(b) by 492 days.

(21) Appl. No.: **11/436,876**

(22) Filed: **May 18, 2006**

(65) **Prior Publication Data**

US 2006/0260183 A1 Nov. 23, 2006

Related U.S. Application Data

(60) Provisional application No. 60/682,293, filed on May 18, 2005.

(51) **Int. Cl.**

A01N 25/34 (2006.01)
A01M 1/20 (2006.01)

(52) **U.S. Cl.** **424/403**; 424/405; 424/409; 424/411; 424/413; 514/875; 514/876; 514/919; 43/132.1; 43/111; 43/112; 43/113; 119/654

(58) **Field of Classification Search** 43/124, 43/131, 129, 132.1; 514/875, 876, 919; 424/403, 424/405, 409, 413, 411, 416, DIG. 10, DIG. 7; 119/654, 655, 653

See application file for complete search history.

(56) **References Cited**

U.S. PATENT DOCUMENTS

1,732,028 A * 10/1929 Reiner 239/36
2,138,040 A * 11/1938 Perry 119/654

2,205,711 A * 6/1940 Banks 119/654
2,764,969 A * 10/1956 Weiss
3,605,321 A * 9/1971 Lazarus 43/131
3,770,199 A * 11/1973 Hoek et al. 239/54
3,814,061 A * 6/1974 Aries et al. 119/654
3,826,036 A * 7/1974 Neugebauer 43/131
3,896,995 A * 7/1975 Lelicoff 239/36
3,951,622 A * 4/1976 Wilk 239/6
3,987,578 A * 10/1976 Rueff
4,017,030 A * 4/1977 Coplan et al. 239/44
4,037,353 A * 7/1977 Hennart et al. 43/129
4,158,440 A * 6/1979 Sullivan et al. 239/6
4,171,340 A * 10/1979 Nishimura et al. 422/36

(Continued)

FOREIGN PATENT DOCUMENTS

EP 93262 A1 * 11/1983

(Continued)

OTHER PUBLICATIONS

Rudolfs, Willem, Chemotropism of Mosquitoes, Mar. 1922, New Jersey Agricultural Experiment Stations.*

(Continued)

Primary Examiner — Joshua J Michener

(74) *Attorney, Agent, or Firm* — James Creighton Wray

(57) **ABSTRACT**

A membrane enclosed fluid diffusion system for insect attractants and repellents, auto thermostatic heaters, and chemical delivery using an additive and/or selectively permeable membrane that interacts with the enclosed fluid to maintain steady delivery rates over a range of temperature and humidity. Systems can be formed with permeable membranes, impermeable membranes, chemical hydrates, wicks, scent fluids, fuel fluids, catalytic heaters, energy conversion devices, visible images, infrared images, trapping systems, sound systems, electronics, and apparel. The device results in efficient and effective devices for mosquito control drug delivery, and portable heaters.

53 Claims, 7 Drawing Sheets

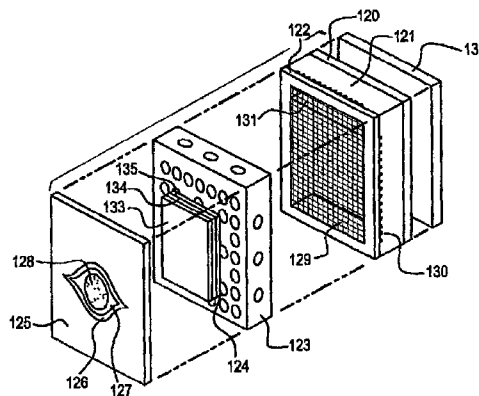
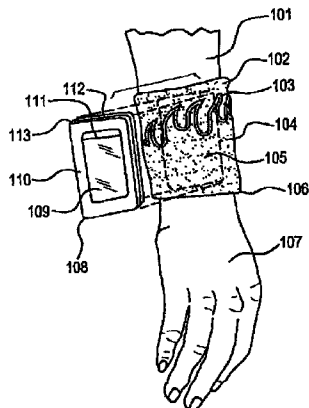

U.S. PATENT DOCUMENTS

4,678,583 A 7/1987 Willson, III et al.
 4,765,982 A 8/1988 Ronning et al.
 4,780,114 A 10/1988 Quinn et al.
 4,804,142 A * 2/1989 Riley 239/56
 4,808,408 A 2/1989 Baker et al.
 4,971,605 A 11/1990 Tarman
 5,221,535 A 6/1993 Domb
 5,364,626 A * 11/1994 Hasegawa et al. 424/403
 5,644,866 A * 7/1997 Katsuda et al. 43/129
 5,669,176 A 9/1997 Miller
 5,711,955 A * 1/1998 Karg 424/409
 5,738,862 A * 4/1998 Abraham 424/403
 5,798,385 A * 8/1998 Marin 514/512
 5,799,436 A 9/1998 Nolen et al.
 5,839,221 A * 11/1998 Ron et al. 43/132.1
 5,854,284 A * 12/1998 Abraham 514/511
 5,975,427 A * 11/1999 Harries 239/34
 6,244,518 B1 * 6/2001 Pogue 239/36
 6,267,953 B1 * 7/2001 Bernier et al. 424/84
 6,289,888 B1 9/2001 Welles

6,296,866 B2 * 10/2001 Karg 424/409
 6,362,235 B1 3/2002 Nolen et al.
 6,372,242 B1 * 4/2002 Gutierrez 424/411
 6,534,079 B1 3/2003 Munagavalasa
 6,662,491 B2 * 12/2003 Flinn et al. 43/132.1
 7,093,770 B1 * 8/2006 Moran 239/36
 2003/0041505 A1 * 3/2003 Flinn et al. 43/132.1
 2004/0128902 A1 7/2004 Kollars et al.
 2005/0163829 A1 * 7/2005 Hoenzelaer 424/448

FOREIGN PATENT DOCUMENTS

WO WO 03/031874 4/2003

OTHER PUBLICATIONS

Gjullin, C.M., Effect of Clothing Color on the Rate of Attack of *Aedes* Mosquitoes, USDA, 1947.*
 Brett, G. A., The relative Attractiveness to *Aedes aegypti* of Certain Coloured Cloths, Transactions of the Torsal Society of Tropical Medicine and Hygiene, vol. XXXII. No. 1. Jun. 1938.*

* cited by examiner

FIG. 1

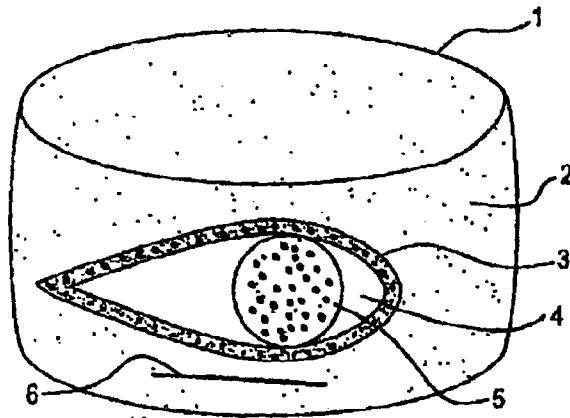

FIG. 1A

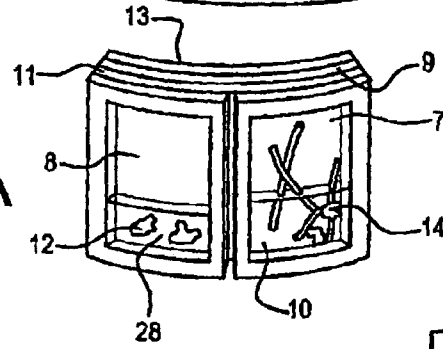

FIG. 2

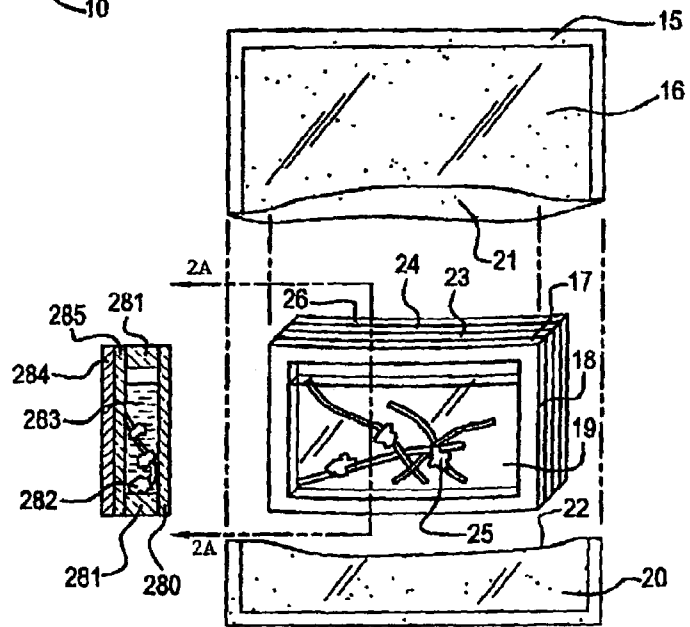

FIG. 2A

FIG. 3A

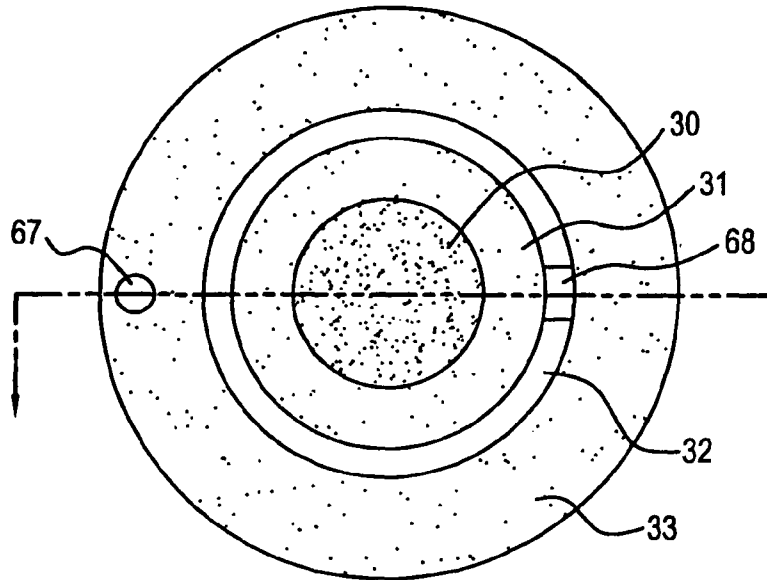

FIG. 3B

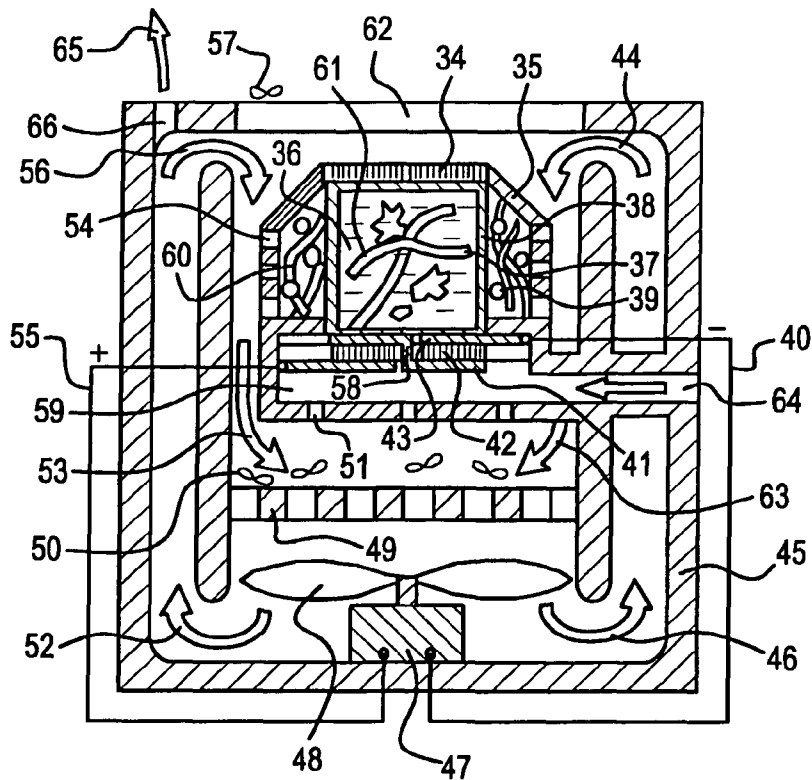

FIG. 4A

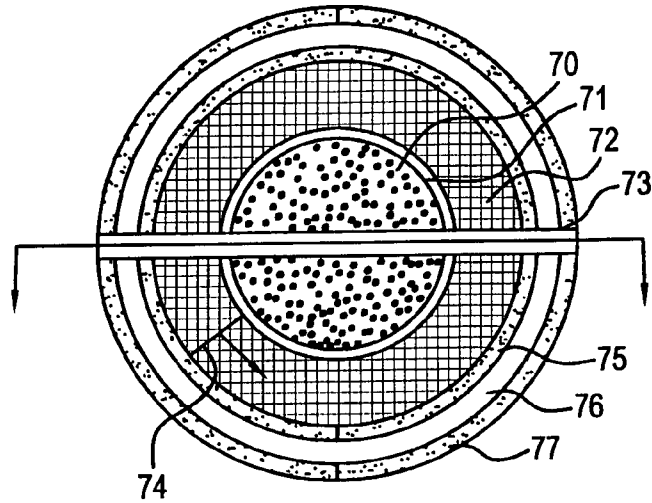

FIG. 4B

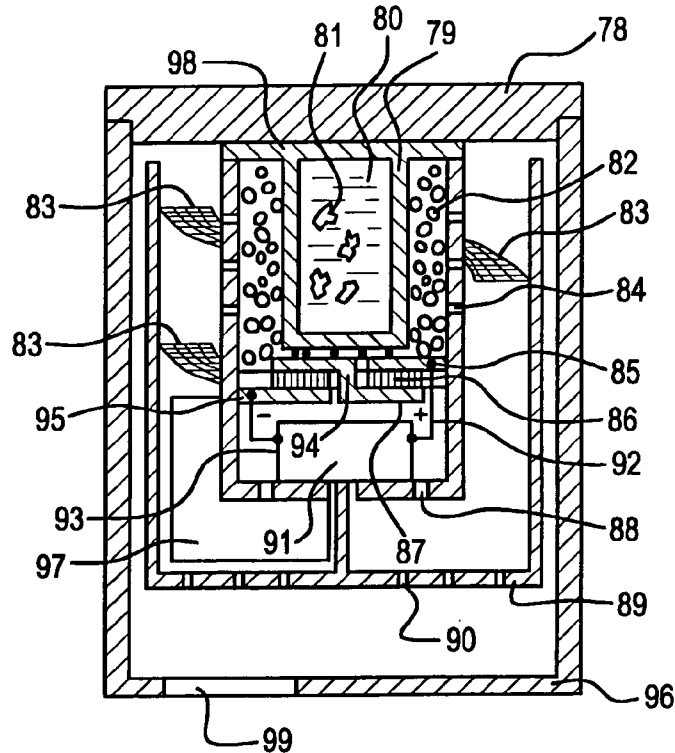

FIG. 5

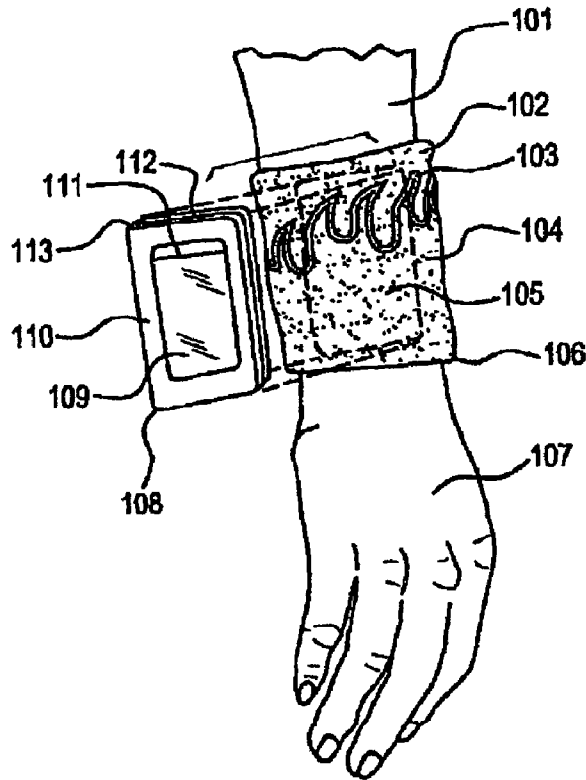

FIG. 6

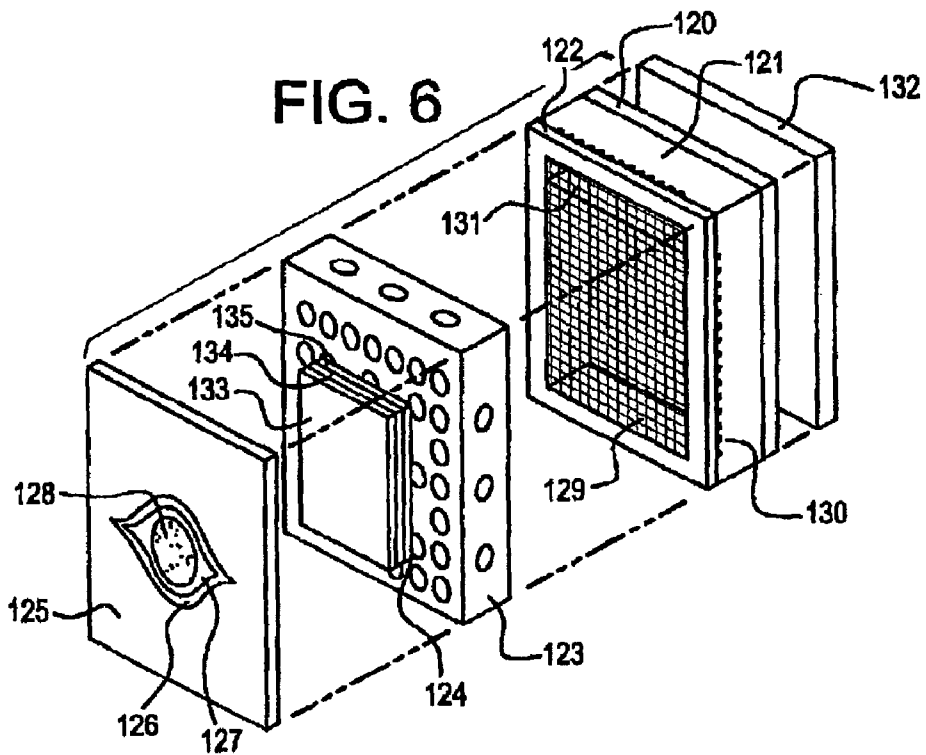

FIG. 7A

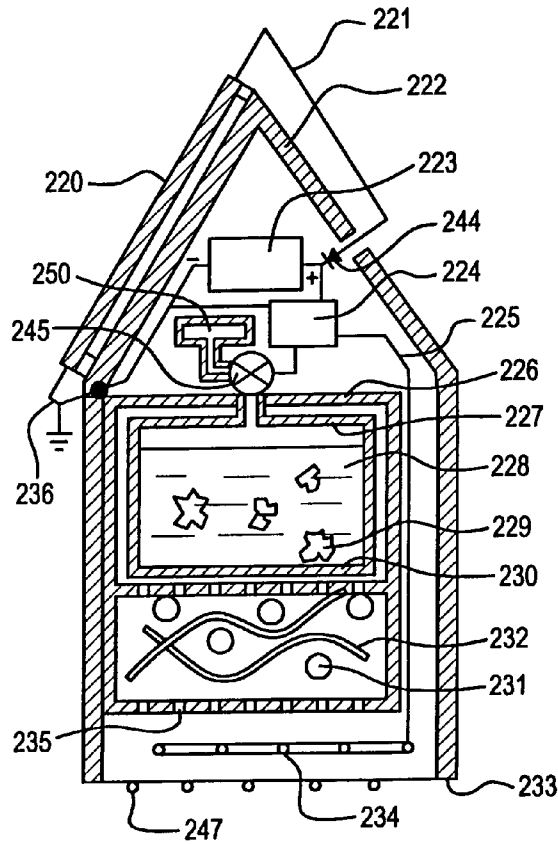

FIG. 7C

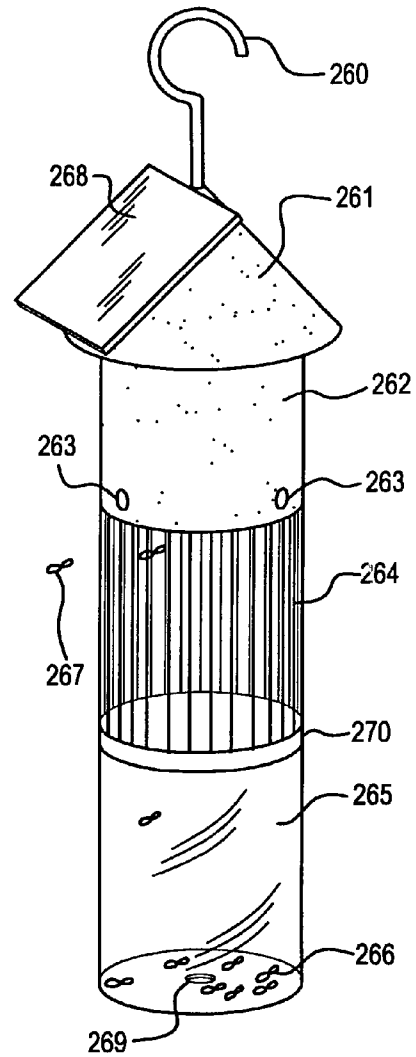

FIG. 7B

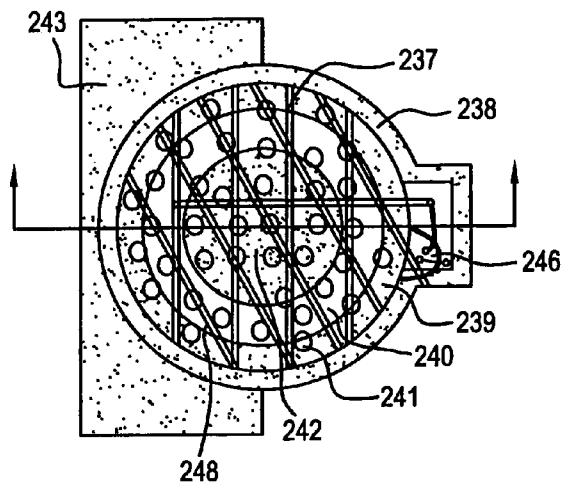

FIG. 8

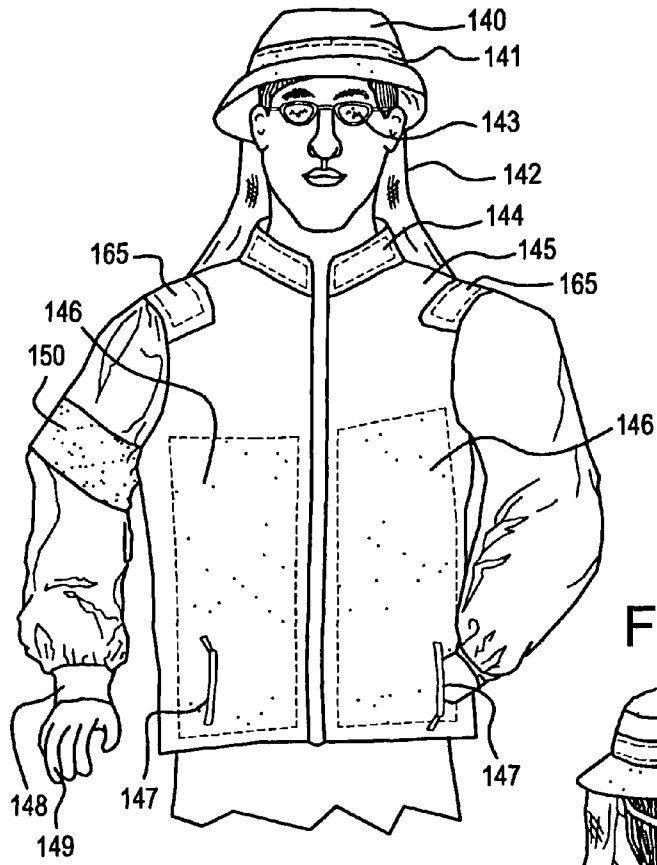

FIG. 9

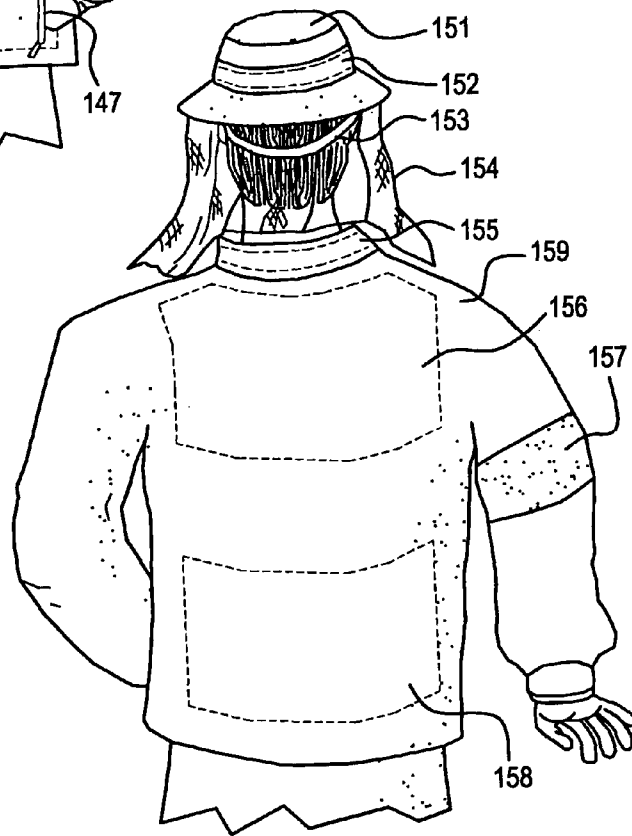

FIG. 10

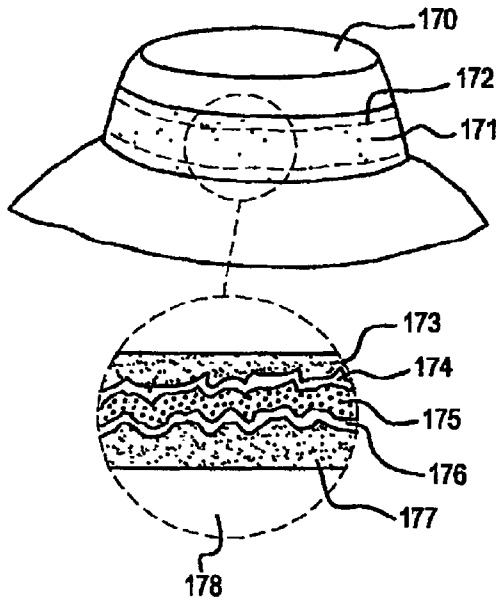

FIG. 10A

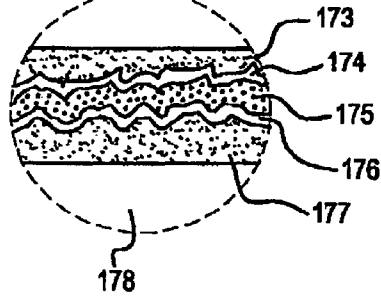

FIG. 10B

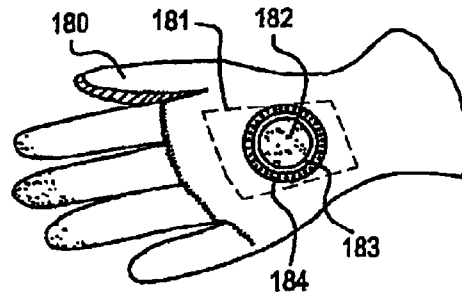
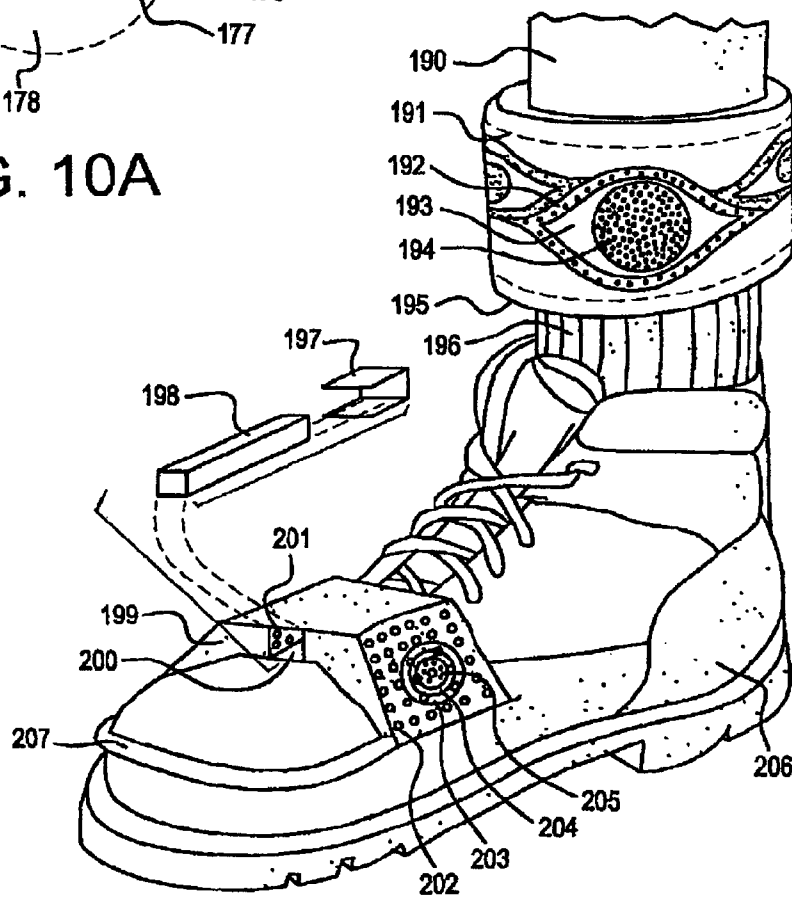

FIG. 11



**INSECT REPELLENT AND ATTRACTANT
AND AUTO-THERMOSTATIC MEMBRANE
VAPOR CONTROL DELIVERY SYSTEM**

This application claims the benefit of U.S. Provisional Application No. 60/682,293, filed May 18, 2005, which is hereby incorporated by reference in its entirety.

BACKGROUND OF THE INVENTION

To attract, repel, or trap arthropods such as insects, mosquitoes, chiggers, flies, fleas, and ticks, systems typically take advantage of their specific behaviors of search, locate, or avoidance. Mosquitoes in particular have a sophisticated array of means and behavior to locate their prey and avoid hazards.

Mosquitoes can detect distant carbon dioxide emissions and moisture. Over 50 chemicals, such as octanol, and lactic acid, have been identified as attractants to mosquitoes and presumably have been used as chemical signatures of their prey. Mosquitoes can detect the warm surfaces of their prey and can distinguish between cold and hot surfaces and avoid those that are not within typical body temperatures of their prey. They are attracted to contrasting and colored surfaces and are attracted to light, including infrared. It is reported that they are attracted to sounds and motion and will be disturbed by flashes of light, sounds, vibrations, and wind.

Typical mosquito repellents, such as N,N-diethyl-3-methylbenzamide (DEET), in most cases, have been found to simply interfere with the mosquito's sensors impairing their ability to track carbon dioxide and presumably other scents also. There is some evidence that DEET and other chemicals on or absorbed by the skin kill parasites that have been injected by the insects or arthropods. But ultimately DEET, on the skin and sound repellents have not prevented some of the insects from finding skin and subsequently stinging. When DEET is applied to the skin between 5.6% and 15% will be absorbed through the skin and into the blood stream of the user.

The effects of repellents are generally to act as an anesthetic; they should not be ingested or applied to open wounds and in excessive cases, topical application has lead to death.

SUMMARY OF INVENTION

The above patents are incorporated herein by references in each of their entireties, and particularly, Hockaday PCT patent application WO 03/031874 A1 "Membrane Catalytic Heater" is incorporated herein by references in its entirety.

Mosquito Behavior

Mosquitoes have the behavior of feeding within certain temperature ranges, low wind conditions, and at dawn and dusk. They will avoid smoke of fires and intensely hot surfaces, ignore cold surfaces and will ignore a variety of chemicals that are typically emitted by vegetation such as methanol.

I have found in my research that mosquitoes are still able to track and locate a human which has a fresh coating of DEET mosquito repellent on his skin, although at a reduced rate. I have found that with repellent ampoules the mosquitoes had the surprising behavior of flying straight toward the repellent ampoule and landing on the area between a red, yellow, and black cloth surface. This suggested that the mosquitoes, once they are close to the prey, are not using the carbon dioxide emission and chemical scents to track the prey, but are using infrared and visible light to close in on their prey.

An explanation of this behavior may be that in their environment the principal preys of mosquitoes are feathered birds and furry mammals. The principal area where skin is usually exposed and is available to mosquitoes to penetrate to blood vessels near the nose and around the eyes, since the rest of the body is covered in feathers and fur, plates, or thick skin. The edge of the eyes are a particularly attractive target because the nose area can be surrounded by thick skin and the action of breathing can disturb landing and even suck in the insects. The center of the eye is unsuitable due to the lack of blood vessels and the rapid response of the eyelids should push the insects off the eye. Therefore I expect that insects that seek blood will target the border between the eye and the fur or feathers, what is usually called pink tissue. Thus I expect efficient blood seeking insects to home in on the edges of the eyes.

The eyes of animals also distinctly stand out in the environment. The eyes are near the body temperature of the animal, are wet, and have a dark center, a colored iris, a white perimeter, and then have colored or pink eyelids or edges, which are then surrounded by fur, scales, or feathers. The eyes are expected to emit an infrared light spectrum typical of water, or blood at about 36° C., and many of the chemicals traces of the animal are emitted through the thin skin or membranes. Eyes also periodically move. This motion may also provide a distinct visual signature of the prey to the mosquito. The invention uses this expected targeting behavior to eyes by having an attraction decoy target that looks like or has features of an eye.

Mosquito Targeting Sequence

An expected mosquito targeting sequence is to initially activate when elevated carbon dioxide or chemical scents are detected, and to fly toward the concentration gradient plume of chemical traces. Periodic puffs of carbon dioxide and metabolic chemicals may further confirm the target is an animal rather than a plant. At closer range when the eyes or infrared sensors of the insect detect an eye or surface in the proper temperature range and emission, the mosquitoes fly toward it. Some surfaces may be animal body temperatures but are not emitting a light spectrum of a wetted surface that is characteristic of the eye such as metal surfaces and non-living objects. Use the sound of other female mosquitoes flying near the prey at 500 Hertz to help locate the prey. As approach is made toward the eye, the mosquitoes move toward the edges and in particular the contrast color perimeter area and the pink tissue.

The optical resolution of the insects eyes and infrared structure, due to the small size and faceted nature, and long wavelength light, and are expected to only allow close range use, but will allow the insect to lock onto a small specific target area in close range compared to the chemical traces such as lactic acid from the whole animal's skin and exhalations. Avoiding and flying away from sudden airflow, this behavior could be a desirable survival instinct because if the located target is the nose of an animal, being sucked in is fatal. As contact descent is made on the pink tissue, chemical traces such as lactic acid should increase confirming the target. Motion is expected from the eye and blood circulation vibrations to further confirm this is a live animal. Mosquitoes avoid the rapid motions of the eye opening and closing. They repeat the approach until stable pink tissue has been landed upon where upon proboscis is inserted and blood drawn. The blinking of the eye will only cause minor flying avoidance, flying

only high enough to avoid eyelashes and not far enough to stray into the nostrils or loose the eye target.

Mosquito Attraction Innovation

One of the innovations of this invention is to create a decoy for the mosquitoes to land on if they are in close range, emit sufficient sensor jamming chemicals to block the mosquito's chemical sensors such that they will have only visual cues and ineffectually land on the decoy instead of the human skin. The decoy could also kill the mosquitoes such as with an electrical pulse, laser light pulse, contact insecticides, insecticides inside membranes, vaporized insecticides, or a trap. The mosquito obtains the maximum dose of sensor jamming chemicals, or poisons, by approaching and landing on or drawing fluid out of the decoy. Bacteria or viruses harmful to just the mosquitoes could be delivered with decoy contact.

A flash of light could also be used to overload the light sensor system of the mosquito, hopefully blinding the insect and/or causing them to fly away from the target and also preventing them from making return visual attacks. It may be possible to interfere with the insect insertion mechanism by coating or filling the decoy target with a chemical that can interfere with the proboscis or digestive system of the insects. The chemical blocking strategy, when the insect is close, is usually insufficient to divert them from reaching the prey.

It may also be necessary, to be effective, to disturb the mosquitoes sufficiently and periodically so that they will fly far enough away so that they will be unable to use visual cues to find alternate victims. This can be done with puffs of air and flashes of light or sound. Killing the mosquito can be accomplished by puffs of insecticide, surface coatings of insecticide, such as pyrethrum, permethrin, a sticky entrapping surface, an electrical pulse, or insecticide inside an ampoule.

Rather than allow the mosquito to repeatably attack the decoy and possibly then also attack the human as a secondary target, a strategy might be to deliver a chemical to satisfy their appetite, or simulate sudden motion of the victim to move the mosquito away. Examples of these are citronella, glucose (appetite affectors), sound bursts, puffs of air, and small flashes of light. It may be possible that an intense infrared light flash might overload their light sensors to temporarily or permanently blind the mosquitoes.

A light flash might be able to convince mosquitoes momentarily that it is midday and to stop their hunting behavior. It should be mentioned that along with sensor jamming and decoy devices it would help if the user wears dry clothes that have low emissivity to be less attractive and not to have the infrared signature of a wet surface, to help make the decoy the more attractive target.

From the literature search, DEET, currently the most effective sensor jamming chemical, has not been shown to be harmful to the human body when used topically and periodically, but typically 6-15% is absorbed through the skin when applied on the skin. It is recommended to use lower concentrations on children's skin. The highest dose of DEET will remain on the skin for roughly 8 hours. This means an application of the most concentrated DEET sold must be applied every 8 hours for continuous performance. DEET can also be washed off. For lesser concentrations its use is more frequent.

The application of DEET does not repel mosquitoes, it simply interferes with their chemical sensors, so it does not prevent the mosquitoes in the closest proximity from finding a host without the chemical clues. The repellent ampoule can also contain a fuel to make carbon dioxide through combustion or a fuel cell. Electrical power can be produced by the combustion driving a heat engine, thermoelectric device or

electrochemically with a fuel cell to be used to drive electronics, mechanical devices, and fans. The electronics could also drive a light source, and/or sound sources to attract, disturb, or repel insects. The fans and mechanical devices can be used to trap the mosquitoes. There could be many other means of powering electronics such as batteries, utility electricity, solar cells, and windmills.

This invention can be a wrist, ankle, hat, or neck strap, separate or as part of the clothing. Other systems can be stand-alone attractors, traps and general mosquito disabling systems at the perimeter of the desired clear areas. The stand-alone systems can use a variety of heat and carbon dioxide sources, including catalytic heaters, batteries, electric heaters, fuel cells, and solar light warmed surfaces and solar warmed thermal masses.

This invention uses a permeable membrane containment of insect attractants and/or sensor interfering compounds, combined with any number of colored surfaces, infrared emitting surfaces, light and contrasting surfaces and body heat or heater to form a sting defeating system. The membrane containment can have a permeable wall facing the outside air and an impermeable membrane facing the body, keeping chemicals from going into the skin or to the interior of the system.

A variety of technologies can be integrated with this system including catalytic heaters, fuel cells, thermoelectrics, batteries, electronic sensors, traps, fans, chemical luminescent light sources, light emitting diodes, and sound generators. The membrane can also be selectively permeable to permit emitted chemicals to diffuse out and can have a reduced water incoming diffusion to maintain a steady delivery even in a very humid environment.

A water-absorbing chemical that does not diffuse through the membrane and is insoluble in the emitted chemicals can act to maintain the vapor pressure of the emitted chemicals by capturing the water that does diffuse through the membrane. This membrane delivery of chemicals can be used to deliver fuels to a catalytic heater and to generate carbon dioxide and maintain the heater within the insect attractive temperature.

Control of the fuel contact with the membrane with active controls, such as with a pump or by allowing the boiling of the fuel to push the fuel away from the membranes surface, can be used to control the catalytic heaters temperatures. It is possible to have membranes that reduce their permeability of fuel at higher temperatures creating a temperature regulating mechanism.

I have found that the delivery of repellents through membranes will track the vapor pressure of the chemicals, and rises exponentially with temperature which can lead to excessive delivery of repellents at high temperatures and ineffective delivery rates at low temperatures. Thus, it is important to regulate the temperature or the diffusion rate of the ampoule at different temperatures to provide an optimum delivery of repellents or attractants, besides also being an infrared attractive target for insects.

This invention also adds a material that has a low diffusion rate through the membrane into the ampoule. When the ampoule goes above a certain temperature, it releases water or a chemical that reduces the vapor pressure of the diffusing chemicals. Another effect of the released chemical, such as water, can also deliver a vapor through the membrane that acts as a retardant to the catalytic utilization of the fuel chemicals. This mechanism can be used to moderate the delivery of chemicals over a wide range of temperatures, or can act as temperature regulated fuel delivery to a chemical reaction, catalytic heater, or fuel cell.

The chemical additive that regulates the chemical vapor pressure can also serve the function of a chemical vapor

pressure maintainer at low temperatures by absorbing impurities that can diffuse through the membrane, such as water. An example of this temperature chemical regulating system is to add sodium sulfate hydrate (Glabers salt) to methanol fuel with DEET in a silicone rubber ampoule. When the temperature of the ampoule goes above 32.3° C. the de-hydration of the salt will occur. This dehydration absorbs heat energy and the released water will dissolve into the methanol and DEET, reducing the vapor pressure of the methanol and DEET.

The initial effect is to create an isothermal condition in the fuel as the salts absorb energy, which can be useful in holding a constant temperature for a while in passive body heated or solar heated systems. The reduction of the vapor pressure throttles the fuel to the catalytic heater reducing heat output and creating a dynamic equilibrium between the fuel delivery and heater output, resulting in an auto thermostatic system. At low temperatures if the sodium sulfate is not fully hydrated it can absorb water that can diffuse into the ampoule and reduce the vapor pressure of the diffusing chemicals, thereby maintaining a high delivery rate at low temperatures.

This auto-thermostatic system can be used in practical thermostatic heater devices where local spatial control of a distributed heater is important and where simplicity of operation and construction is needed. Examples of these kinds of devices are personal heaters on people, insect attraction systems on or off the body, large area heaters, fuel cells, and machinery heaters, food heaters, food defrosting heaters, anti freezing heaters for materials and structures, and heaters for materials and structures.

The fluid diffusion reduction or stabilizing of this system at higher temperatures can be used in systems where steady delivery of a chemical without heating is needed even though the system is operating over a range of temperatures. Examples of non-heated steady delivery applications are passive mosquito repellent delivery and passive transdermal patch drug delivery on arms and legs and off the body.

This patent adds new features upon a co-pending application referred to as Membrane Catalytic Heater (PCT Patent application number WO 03/031874 and provisional patent application No. 60/327,310, both of which are incorporated herein by reference in their entireties) in which fuel vapor and air (or other means of oxygen supply) are supplied to a catalyst. The catalyst promotes the flameless combustion of the fuel, releasing heat. The liquid fuel is supplied through the use of a selectively permeable membrane, such that only the fuel vapors diffuse through the membrane and are fed to the catalyst. The catalyst is placed on a support, and both the catalyst and the support rest on a porous material.

Alternatively, the catalyst may be supported by the selectively permeable membrane. The supply of fuel to the selectively permeable membrane and the exact identity of the membrane serve as a way to regulate the degree of heating provided by the catalytic heater. The selective molecular filtration of the fuel through the membrane keeps the catalytic heater from being contaminated from impurities in fuel, such as salts. The selective permeability of the membrane to fuel such as methanol and not the product water reduces the fuel contaminated with back diffusion of product water and maintains the fuel concentration subsequently at a steady rate of fuel delivery.

Another feature of the membrane catalytic heater invention is an additional coating, which protects the combustion catalyst from contamination. It also serves the purpose of adhering the catalyst powders to the substrate on which they are supported. The coating also has certain permeability to the fuel and the products of the combustion reaction. This coating can also serve the purpose of limiting the catalytic combus-

tion rate and therefore serves as yet another regulating mechanism in the invention. The coating also protects the catalytic surfaces from contamination and can enhance the catalytic effects. The coating can also have an affinity for the fuel and oxidizer and products to increase the effectiveness of the fuel.

The catalytic heater can be incorporated into a system for various applications. One of the unique features of using a liquid fuel with the selectively permeable membrane in proximity to the catalytic heater is that when the fuel reaches its boiling point it removes fuel by boiling away from the catalytic reaction site and subsequently limits the maximum temperature. The vaporized fuel can be condensed in a heat exchanger and can deliver the thermal output of the heater efficiently. This fuel boiling mechanism along with the back diffusion of carbon dioxide and nitrogen can also be used to keep the fuel homogenous and self purging. By keeping the fuel homogenous and not in direct contact with catalysts, the heater can easily be purged of fuel contamination by draining the fuel.

20 Critical New Features Include, but are not Limited to, the Following:

1. Permeable membrane containing the chemical emission chemicals.
2. An additive to the contained chemicals to moderate or reduce the vapor pressures with higher temperatures or maintains a high vapor pressure at low temperatures.
3. An impermeable membrane containing the permeable membrane chemicals.
4. An impermeable barrier between the diffusion ampoule and human to reduce contact with the insect interfering chemicals.
5. Catalytic heaters.
6. Insect sensor jamming chemicals in the ampoules.
7. Insect attraction chemicals in the ampoules.
8. Insect sensor jamming and attraction chemicals in the ampoules.
9. Insect distracting or repelling mechanism in the ampoules.
10. Insect killing, infecting, vaccinating, satisfying, or disabling chemicals in the ampoules.
11. Images of eyes and colors and patterns typical of insect prey.
12. An infrared heat emission pattern typical of the insects' prey use to attract insects.
13. Incorporating insect attracting, distracting, blinding, or repelling light systems such as a flashing infrared light.
14. Incorporating insect attracting or disturbing sounds.

These and further and other objects and features of the invention are apparent in the disclosure, which includes the above and ongoing written description with the drawings and the claims.

BRIEF DESCRIPTION OF THE DRAWINGS

FIG. 1. Eye image cloth wristband with a dual insertable repellent scent ampoule.

FIG. 1A is a detail of the insertable repellent scent ampoule for use in the wristband shown in FIG. 1.

FIG. 2. Chemical diffusion ampoule and sealed packet.

FIG. 2A is a cross section of the chemical diffusion ampoule and sealed packet taken along line 2A-2A of FIG. 2.

FIG. 3A Fan driven mosquito trap system top view of heated spot.

FIG. 3B Fan driven mosquito trap system side view cross-section.

FIG. 4A Rotating helical mesh trap top view of heated spot.

FIG. 4B Rotating helical mesh trap side cross-sectional view.

7

FIG. 5 Wrist band shown on human wrist and diffusion ampoule.

FIG. 6 Membrane catalytic heater attractor exploded view.

FIG. 7A Cross-sectional view of a high voltage electrical discharge mosquito trap with catalytic heater, with photovoltaic cell electrical power source.

FIG. 7B Bottom view of cross sectional view of high voltage electrical discharge mosquito trap with catalytic heater, with photovoltaic cell electrical power source.

FIG. 7C Exterior view of the high voltage electrical discharge mosquito trap with, photovoltaic cells and sound transducers, protective wires and catch jar.

FIG. 8 Front view of upper body of possible locations of heaters, insect repellent, insect confusion, or insect attraction devices incorporated into apparel.

FIG. 9. Back view of upper body of possible locations of heaters, insect repellent, insect confusion, or insect attraction devices incorporated into apparel.

FIG. 10 shows a hat with insect repellent, insect confusion, or insect attraction band.

FIG. 10A is an enlarged view of the band color pattern on the hat band shown in FIG. 10.

FIG. 10B Glove with repellent ampoule and visual decoy.

FIG. 11 Shoe heater and ankle band.

DETAILED DESCRIPTION OF PREFERRED EMBODIMENTS

In FIG. 1 a view of the cloth wrist or ankle band 1 with the repellent ampoule 7 shown removed from the interior of the wristband 1. The band 1 is made with cotton, Cool Max® polyester fabric, silk, or an elastic weave Nylon fabric (texollini, 2575 El Presidio St., Long Beach, Calif. 90810). The band 1 is cut and sewn in the form of a circular tube with an interior volume (pocket) 6. The pocket 6 in the band can have sewn restrictions to contain the rubber ampoules 7, 8 just under the eye pattern 3. Access to the pocket is provided by a slit opening 6 which is shown on the outer surface of the band. The slit opening 6 can also be placed on the interior of the band 1.

An eye like pattern is inked on the band 3, 4, 5. Features of the eye are a dark central area 5 colored black simulating a pupil. It may also be effective to simply have a round hole viewing the underlying ampoule being colored black. The pocket can also be lined or made with a membrane or fabric that has low permeability or is impermeable to the chemicals to be delivered to achieve directed chemical diffusion out through the eye pattern of permeable or open holes in the fabric. The pocket also provides a homogenizing cavity to mix the two the different scents from the two ampoules 8,7 in this example. This hole pattern scheme also has the feature that the surface of the ampoules 7, 8 are expected to be hotter than the outer fabric surfaces by closer contact to the skin and a good thermal conductor of the users heat and thereby simulate the thermal characteristics of an eye more effectively.

Around or adjacent to the black spot 5 is a printed yellow or white area 4. This simulates iris and the conjunctiva "white" of the eye. Surrounding the yellow or white area 4 is a rim pattern of pink, red, or magenta 3. This simulates the eyelids and surrounding exposed thin skin near the eye of an animal. The remainder of the band 2 is fabric dyed with light colors such as light brown simulating the lower emissivity of the remainder of the animal that is fur or plate covered. These colors of the patterns that were chosen to simulate the emissivity surfaces of typical prey of mosquitoes. Other more abstract patterns have been used effectively with similar adjacent colored areas shown in FIG. 5.

8

It is also desirable to match the colored areas 3, 4, 5 with the infrared spectrum that mosquitoes also utilize in identifying prey. In particular the entire eye area 3,4,5 ideally would emit an infrared spectrum matching that of a moist eye, which is dominated by water. Thus a water retaining material such as cotton fibers, cotton cloth, or hydrogel could be incorporated into the pattern.

The repellent ampoules 7, 8 shown in FIG. 1 are made with two silicone rubber sheets 7,8 from Specialty Silicone Fabricators Inc., 3077 Rollie Gates Dr., Paso Robles, Calif. 93446, the thickness and composition of each can be adjusted to have the two ampoules, in this example, deliver a constant ratio of attraction, interference, and satiation chemical fluids. Many ampoules with volume, surface area, membrane material and thickness can be used to deliver targeted chemical fluid (gases or liquids) ratios. It is anticipated the customer preferences for particular odors can be accommodated by the user selecting from a range of perfume loaded ampoules.

A back silicone rubber sheet 0.5-mm thick 9 and a 25-micron thick aluminum foil sheet 13 are cut out. The high permeability sheet 7 and the low permeability sheet 8 of silicone membrane and a spacer frame of silicone rubber 11 are cut out. A back wall consisting of an aluminum foil sheet 13 glued to a silicone rubber membrane 9 is glued together with silicone sealant. The outer sheets 7,8, frame 11 and back sheet 9,13 are silicone sealant glued along the frame 11 to form the hollow cavity ampoule, along with a suspension agent such as fumed silica, dry crystals or anhydrous sodium sulfate 12,14. The curing of the silicone sealant can occur in a humidified atmosphere above 33 C to allow the silicone sealant to cure, while preventing the sodium sulfate 12 from hydrating.

Alternatively the sodium sulfate and fumed silica 12 can be obtained in a fine powder form and injected as slurry with the fluids 10, 28 after the silicone ampoule is formed. Once the silicone sealant is fully cured the ampoule is filled by a needle injection from a syringe with DEET liquid, and attractants such as folic acid, citronella, and octanol and perfumes 10. The second ampoule can be designed with a thicker or composite membrane 8 for the high volatility liquids such as acetone, methanol, and ethanol 28.

The silicone rubber 7,8,11 has a high diffusion permeability and chemical resistance for the DEET, octanol, folic acid, methanol, ethanol and acetone while having a low permeability for the sodium sulfate. The rubber ampoule 7,8 is then inserted into the band 1 by folding the rubber ampoule 7,8 and stretching the elastic fabric of the pocket opening 6 with the aluminum foil side 13 facing the interior of the band 1. The rubber ampoule 7,8 is then unfolded and held in the square pocket 6 in the wristband 1 underneath the eye pattern 3,4,5.

The assembled bands 1 can then be worn on the wrists, ankles, arms, forehead, and neck and on hats. It could also be configured to have an adhesive underside coating and be worn like a bandage. They can also be placed on animals. They may also be placed on warm objects. These bands 1 are expected to act as sweat bands and wick sweat toward the more water retaining patterned area of the band. This effectively can add the user's scents to the decoy eye pattern area of the band. The expected behavior of female mosquitoes is to be attracted first by the carbon dioxide emissions and scents of the user and the ampoule. The mosquito will also be encountering the low volatility compound 10 and the high volatility compounds 28 emissions from the ampoules 7,8 that is warmed by it's placement on the body of the user.

Initially the scents are designed to attract the mosquitoes preferentially to the band 1. When the mosquito is nearing contact the DEET will interfere with the chemical sensors of

the mosquito and they will use only infrared and visual cues. If she is close enough, within roughly three meters, she will be attracted to the dark pupil pattern **5** and infrared emissions on the band **1** and at close range land on the border area **3** of red or pink and the white area **4** of the decoy. If not close enough for visual cues she may then wander off with some dose of DEET to hamper her long-range ability to find prey. By landing on the decoy **3,4,5** the Mosquito will obtain a high concentration of DEET vapor disabling and interfering with her chemical sensors.

Chemicals such as citronella may confuse the mosquito's appetite. We have observed mosquitoes repeatably attacking the decoy **3,4,5** when only DEET was used. If the user moves or brushes the mosquito away this may be sufficient to put them far enough away from visual cues to attack again, reducing the chances that she will be able to find an authentic victim. The ampoules **7, 8** can be designed with a desired diffusion delivery rate of DEET and scents **10, 28** in sufficient volume to effectively deliver a steady chemical vapor for days.

The aluminum foil wall **13** of silicone rubber ampoule **7** blocks direct contact to the user with the DEET and other scents **10, 28**. This reduces the amount of DEET and scents **10, 28** absorbed by the user. By wetting the band **1** with water or sweat from the user it is expected to increase the attractiveness of the decoy pattern **3,4,5**.

In FIG. **2** a diffusion ampoule **18** and the surrounding impermeable package **15** are shown. The diffusion ampoule **18** consists of a silicone rubber membrane **17**, silicone frame **23**, back silicone rubber wall **24**, and an aluminum foil backing foil **26** glued together with silicone rubber sealant. Inside the diffusion ampoule **18** are sodium sulfate crystals **25**, diatomaceous earth or fumed silica **19**. Diatomaceous earth, jelling materials, cotton fibers, or fumed silica can be added to the DEET and salt hydrate mixture **25, 19** to maintain contact with the membrane as well as to keep the salt hydrate suspended and to avoid a settling out behavior that can occur because of the higher density of the salt crystals from the DEET and change in dimensions from hydration to dehydration. If the sodium sulfate is to be used as a temperature regulating system with the catalytic heaters or fuel cells, the sodium sulfate **25** is hydrated.

An impermeable package made from two sheets of aluminum foil **16** coated with urethane and polypropylene is heat sealed **15** around the diffusion ampoule **18**. The diffusion ampoule **18** is filled with DEET, attraction compounds **19**, such as lactic acid, and octanol, and sodium sulfate hydrate **25** through a syringe. In FIG. **2** the impermeable package **16,20** is shown torn open **21, 22** to remove the diffusion ampoule **18** to be placed in the mosquito band, trap, or interference device.

In FIG. **2** a cross-sectional view of the ampoule is shown. The outer silicone membrane **280** is glued or heat-sealed to a frame **281** and a back wall **285**. A back wall membrane of impermeable material **284** such as aluminum foil is glued to the back silicone rubber wall **285**. The impermeable membrane **284** may be wrapped around the edges of the frame **281**, (not shown for simplicity) and around some of the front membrane **280** in products to minimize diffusion of chemicals to the skin of the user.

In FIG. **3A** a mosquito trap that uses a catalytic heater and fuel cell and air fan is shown viewing the simulated eye. The simulated eye consists of the central black infrared emission spot **30** that could have a coating or could be made of a material that retains water such as sodium chloride, sugar, or solid polymer electrolyte (Nafion). The eye spot **30** is painted onto a ceramic, aluminum or stainless steel metal cylinder that holds the catalytic burner and a fuel cell. Surrounding the

black eye spot **30** is the simulated iris **31** and conjunctiva "white" of the eye formed by painting the edge of the cylinder with a yellow or white paint, and a material that retains water or has a infrared emission similar to water, such as titanium dioxide, solid polymer electrolyte such as perfluorosulfonic (Nafion®) or sulfinated butyl rubber and polystyrene (DAIS).

It is possible that a permeable ampoule of saline solution and attractive chemicals that match both the electromagnetic and chemical emission of the eyes and skin of animals could be located on, or near the simulated eye. It may be feasible that the attraction ampoule and the fuel ampoule could be the same ampoule or use two different membranes to deliver appropriate chemicals to attract mosquitoes on one side and fuel the catalytic heater and fuel cell on the other side.

Another possible delivery arrangement is to deliver methanol fuel through a silicone membrane capillary tube passing by the catalytic heater and fuel cell, while preferentially accumulating and retaining water and the larger scent molecules such octanol, lactic acid and DEET. Then the remaining fluid depleted of methanol flows into or onto a porous evaporation surface of porous alumina with 0.5 microns to 1.3 micron pores of the eye simulator **30** through a small capillary tube vent (10 cm long 125 micron inside diameter stainless steel tube or through a permeable membrane (500 micron thick silicone rubber membrane, or 25 micron Urethane rubber membrane).

Surrounding the simulated iris **30** and conjunctiva **31** is the throat of the air intake, where the inner walls and the outer walls of the flow tube **32** are coated red or pink, and which has a coating with a infrared emission similar to blood and which retains water, such as Nafion. Outside the throat area is the outer housing **33** and airflow ducting cylinder. This can be made of painted steel with a tan or brown coating to simulate the color of an animals body. A vent **67** for carbon dioxide and scents is used to ensure that sufficient chemical scents are emitted by the trap's recirculation flow. The fresh air intake channel **68** shown crossing the throat **32** brings fresh air into the center of the trap and the fuel cell array.

In operation the central black spot **30** is heated to between 25° C. and 42° C., with a thermostatic temperature target of 36° C. controlled by the fuel distribution bladder or ampoule and catalytic burner and fuel cell. The heat is transferred through the metal central cylinder and the fuel distribution bladder or ampoule. The central spot **30** provides the distinct visual and infrared target for mosquitoes, while the catalytic heater and fuel cells provide the heat to warm the central spot to the needed temperature. The vent hole **67** insures that a fraction of the re-circulated carbon dioxide and scent loaded gas flow of the trap is emitted near the entrance of the trap.

In FIG. **3B** a side cross sectional view through the insect trap is shown. The central spot **34** is shown as a solid plate, made of metal such as aluminum, coated with various coatings mentioned in FIG. **3A**, but it could be permeable silicone rubber, urethane, or porous ceramic or cloth to allow scents and water to permeate its surface to produce an attractive target for the insects.

Behind the central spot **34** is the fuel ampoule **38**. This is shown as a single bladder filled with fluids such as methanol, acetone, folic acid, octanol, DEET, fumed silica **36** and Sodium sulfate hydrate **37**. Diatomaceous earth, cotton fibers **61**, jelling materials, or fumed silica can be added to the fuel and salt hydrate mixture **36** to maintain contact with the membrane **38** as well as to keep the salt hydrate **37** suspended and avoid a settling out behavior that can occur because of its higher density from the fuel and salt crystals and change in dimensions from hydration to dehydration.

The fuel ampoule **38** could be designed in many forms from insertable ampoules to capillary tubes that are filled from a larger pressurized reservoir. Surrounded on the sides of the fuel ampoule is a bed of alumina beads **39** coated with 1% platinum (Englehard, Chemical Catalyst Group, **554** Englehard Dr., Seneca, S.C., 29678), and alumina silicate fibers **60** coated with platinum (Infragas S. p. A., via Lavoresco, 10-10072 Caselle, (TO) Italy).

Enclosing the bed of catalysts **39** is a concentric perforated aluminum cylinder **54**. The outer surface of the perforated aluminum cylinder **54** is coated with a red coating to match the infrared and visual electromagnetic emission of shallow surface blood vessels of skin and eyelids. The catalytic heater **39, 60, 54** catalytically combusts the methanol as it diffuses through the ampoule membranes **38** to the catalytic sites **39, 60** with oxygen which is diffusing from the air flowing **44, 56** past the heater.

Adjacent to the fuel ampoule **38** is a fuel cell or thermopile **58, 43, 42, 41, 59**. Fresh air is drawn in from the outside air through a flow channel **64** to the fuel cell array or thermopile **58, 43, 42, 41, 59**. If a thermopile is used, the air flow channel **64** could be substituted with a heat pipe with a heat fins heat radiator on the outside of the trap. The fuel cell would use the methanol fuel from the ampoule **38** and diffusing oxygen in a filtered manifold **51, 59** to convert the energy in the methanol to electricity and heat. Carbon dioxide and water products of the fuel cell will diffuse away from the fuel cell **58, 43, 42, 41, 59** into the air flow **53, 63**.

If a thermopile is used instead of a fuel cell, the thermopile is heat sinked to the flowing air **53, 63**, and the heat is moved from the catalytic heater into the air **53, 63** flows. Other possible energy conversion devices that could be used are a heat engine coupled to a fan or a heat engine coupled to an electric generator. Photovoltaic cells and batteries can also be the source of electric power as well as utility generated electricity.

Outside of the fuel cell is a perforated plate **51** with a porous polyethylene non-woven sheet to filter the air supply. Electrical connections **55, 40** to the fuel cell or thermopile go to the fan **47, 48**. A battery or electrical storage device and appropriate flap valves to keep the insects in the trap may be used to operate the trap only during insect feeding times. Electronics that sense desirable operating times can control fuel valves or pumps for fuel, turn off and on fans and run attraction lights, vibrations, and sound devices, or even devices to indicate the trap is full or needs servicing could be used.

The fan **47, 48** is shown located behind the insect screen **49**. It should be mentioned that also unsteady or periodic airflow of various fans and means could be used effectively to capture the mosquitoes. The periodic carbon dioxide and scent laden airflows **65** from the vent **66** and vibrations may also be attractive to insects because this matches the breathing of typical prey.

In this trap, filters **49** similar to plankton net cones could be used to move bodies of insects **50** gradually down the filter to keep the net clear of insects and to permit easy disposal of bodies out through an outlet jar, drawer or exit could be used. The fan **47, 48** is placed after the net **49** to avoid fouling from the bodies of the insects **50**. The airflow **53, 63, 46, 52** is drawn through the screen by the fan and is ducted through the outer and inner duct plenum **56, 44** up to the entrance of the trap **62**. The objective of recirculating the airflow is to increase the efficiency of the air flow by using the same air flow's kinetic energy rather than exhausting the air and to make the emissions of the attractant come from the entrance of the trap **62** where the insects are to be attracted. This recirculated air is

also conserving heat energy by avoiding heating cool air and then exhausting warm air. The recirculated air **44, 56, 46, 56** will have a higher temperature and, concentration of carbon dioxide, water, and scents and higher air flow as compared to a system of the same output that is not re-circulated.

A fraction **65** of the recirculated air **44, 56** either by random fluctuations, diffusion, or purposely diverted through the vent **66** at the entrance of the trap **62** is released to the surrounding air. It is important not to allow the carbon dioxide levels go above 4.7%, typical of animal breath, because at higher concentrations carbon dioxide can act as anesthetic to the mosquitoes, and they may avoid the trap.

At the entrance of the trap **62** the airflow **44, 56** is directed by the outer flow housing **45** to the annular entrance **62** around the target **34, 35, 54**. This airflow pattern **44, 56** at the entrance **62** can be arranged with the geometry and size of the outer housing inner flow housing and the target geometry to create a trapping air flow as the insects are attracted to the red perimeter **54** of the target **34, 35**. The airflow **44, 56** may need to accelerate very gradually and radially from the center of the target **34** because some insects such as mosquitoes will avoid high air flow and airflow gradients.

The mosquitoes instinct may betray them, because to escape high winds the mosquitoes should fly down or away from the typical flow gradient, perpendicular to the flow direction. Thus, if the trap is oriented as shown with the target **34** horizontal on the top or the target vertical, the mosquitoes **57** may fly into the opposite trapping **44**, air flow **56**, or further into the trap.

Once the insects reach the red annular air flow entrance **54** the air flow **56, 44, 53** should be high enough, roughly above **5** miles per hour to not enable the mosquitoes **57** to fly fast enough to escape the trap. The insects are carried by the rapid airflow **56, 44**, in annular entrance nozzle **54** past the heater **54, 39, 60** and fuel cell **41, 42, 43, 58** into the filter area **49**. The filter **49** is made with a screen mesh small enough that mosquitoes cannot go through the mesh. The filter **49** as mentioned earlier could be a cone shape and vertically oriented to gradually accumulate the insects to the apex of the cone, where a jar or drawer can be located to be periodically emptied.

In FIG. **4A** an insect trap with a rotating mesh helix **72** is shown. Non-mesh helixes can be used, except that the air will be required to flow through and exit at the bottom of the trap. In this drawing the visual attraction target is a central circular disk **70** that is black colored, and the coating attempts to match the emissivity of moist animal tissue. Surrounding the central circular disk **70** is a light colored rim **71**, such as white or yellow colored, and then the surface of the heater and the helical mesh **72** which is colored pink or red. Outside of the helical mesh **72** are the sidewalls of the helix **75** colored a non-insect-attractive color such as tan or brown. Outside of the helix sidewalls **75** are a flow plenum **76** and the exterior case cylinder **77**.

One option is to have simply a hole or permeability to the central circular disk **70** that reveals the surface of the ampoule, that has a permeable membrane, that is emitting the insect attractants such as lactic acid, octonal, carbon dioxide, and water. Above the attraction target **70** is the support frame **73**, which also serves as an insect viewing shield of the helix **72**. When the trap is operated and the insects are near the target, the leading edge of the helix **74** will not be visible to the insect for half of the rotation. Thus the rotation of the helix achieves a mechanical action of a mesh door that quickly closes and gradually advances into the trap.

In FIG. **4B** a side cross-sectional view of the trap is shown. The central circular disk **98** is shown in cross section with a cylindrical permeable ampoule of fuel and chemical com-

pounds **79,80,81** to attract and interfere with insects. The ampoule walls **79** are made of a permeable material such as a 20% porosity 0.5 micron pore diameter alumina cylinder 5 mm thick with or 1000-mm thick silicone rubber. A silicone rubber film 50 microns thick coating can also be bonded and supported on the outside of the alumina cylinder **79**.

The cylindrical ampoule is filled with fuel, suspension materials, scents, and salts, such methanol, fumed silica, octanol and sodium sulfate are shown **80, 81**. An exterior reservoir and filling tube, not shown, can be used to maintain the fill of the ampoule **79** running along the central components support beam **78**. Surrounding the cylindrical ampoule **79** are catalytic beads of 1% Platinum on alumina **82**.

Adjacent to the fuel ampoule **79** and fueled by the methanol is a fuel cell array **95,94,87,86**. This fuel cell array can be made with techniques shown in patents U.S. Pat. Nos. 5,631,099 and 5,759,712. The fuel cell array **95,94,87,86** receives fuel that diffuses from the fuel ampoule and utilized air that diffuses through the perforations **88** of the cylinder.

The fuel cell **95,94,87,86** can have selectively permeable membranes that allow it to filter the fuel for hydrogen and methanol and retain water and keep the insect bodies and larger hydrocarbons from interfering with the operation of the fuel cells. The fuel cell **95,94,87,86** can run on the hydrogen that is produced by the fuel rich catalytic operation near the fuel ampoule **79**. The fuel cells **95,94,87,86** can be held with electrical insulating substrates such as ceramics that can withstand the high temperature operation of this heater and fuel cell and the corrosive environment of the fuel cell.

The selectively permeable membranes of the fuel cell could be platinum coated palladium supported by a ceramic substrate on the fuel side **85** or silicone rubber on the air side **87**, or the fuel cells themselves have selectively permeable membranes built into the fuel cell electrodes **85, 87**. The air membrane **87** retains the electrolyte and moisture and allows oxygen through such as 30-micron thick silicone rubber.

The fuel cell electrolyte **86** is phosphoric acid doped PBI from PEMEAS GmbH, Industriepark H chst, G864, 65926 Frankfurt/Main, Germany. This particular membrane electrolyte can be leached if excess water is present and flows away from the fuel cell. Thus the membrane filters on the fuel cell serve the purpose of retaining water **95,94,87,86**. These particular fuel cells would ideally operate at elevated temperatures to maintain a low relative humidity around the electrolyte **86** to keep the electrolyte immobile. Thus the catalytic heater and the temperature regulation of maintaining the temperature above 32 C are a synergistic function with the fuel cell.

This fuel cell array shown **95,94,87,86** has individual fuel cells connected in series or could be a single cell. The fuel cell **95,94,87,86** can be made with high temperature electrolytes. The electrical power output wires **92,93** go to the DC electric motor **91** to drive the helical mesh cylinder **83**. The coil of the cylindrical mesh helix **83** is shown with a clearance of less than 1 mm from the surface of the inner catalytic heater **84** and fuel cell perforated cylinder **88**. The mesh cylinder **89** is made of stainless steel mesh or perforations in the cylinder, with mesh openings **90** approximately less than 1 mm in diameter to prevent the insects from being able to fly or crawl through.

A non-porous rotating helix **83** could be used, but then it is essential that the air moved by the helix flow through the pores **90** at the bottom of the rotating cylinder **89**. A deflection plate **97** could be placed on the outside of the inner cylinder **84** to act as a mechanism to stop the air flow that is entrained with the rotation of the helical mesh **83** and possibly be useful in stirring or moving the resulting accumulation of insect bodies in the trap. The deflection plate **97** could also be used as an

insect crushing-grinding mechanism and eventual removal of the insect bodies through the perforations of the rotating cylinder **90**. The outer housing **96** can have openings **99** to allow crushed insects bodies to fall through to the ground outside the trap while securing the motor and catalytic heater. The outer housing **96** has a tan non-insect-distracting coating.

In FIG. 5 a vapor emitting wristband **106** is shown. This wristband **106** is made with wicking fabric to draw moisture from the skin contact out to the surface of the wristband. Cool Max® polyester fabric, silk, or an elastic weave Nylon are possible construction materials. Woven polypropylene and non-woven polypropylene are possible materials. On the outer surface the fabric can have a zone **102, 103,104** which is treated to have an infrared emissivity similar to skin, water, or blood such as a coating of titanium dioxide. Other possibilities are to make the pattern **102,103,104** sewn onto the wristband made of dyed cotton fabrics.

On the outer surface of the wristband is a pattern of a black area **104**, yellow area **103** and a red area **102** dyed into the wristband **106**. Within the wristband **106** there is a hollow cavity **105** for the membrane ampoule. There is a pocket opening on the inside of the wristband, not shown, to allow the membrane ampoule to be inserted into the wristband. The ampoule **108** can be designed to go around much of the circumference of the human wrist **10**, but has been shown for simplicity to only be within a fraction of the wristband. It is also possible to have multiple ampoules and pockets.

It may also be necessary to have multiple ampoules that are designed with different membranes and thickness to deliver different scents to achieve proportioned air concentrations for desired effects of attraction, repulsion, or interference. An example is that acetone and lactic acid have different diffusion rates through silicone rubber, and are both attractants and need to be delivered at a constant ratio to be most effective. Thus two separate ampoules can be designed with different volumes, effective areas, and membrane properties to do this.

The membrane ampoule **108** is made of a 1 mm thick silicone rubber sheets **109,113** silicone sealant glued along the perimeter **110** and an impermeable back layer **112**, which could be silicone rubber laminated around aluminum foil. The membrane ampoule **108** is filled with chemicals **111** to be vaporized, such as 100% DEET, with a syringe through the silicone membrane after the ampoule **108** has been sealed. Alternatively the ampoule can be partially sealed to form a pouch with an open end and the pouch is filled with the vaporizing chemicals, and then the complete sealing of the pouch is done.

To operate the arm band mosquito repellent device **106** shown in FIG. 5, the membrane ampoule is removed from a sealed pouch **16** as shown in FIG. 2 and is inserted into the internal pocket of the armband **105** under the colored patterns **104,103,102**. The membrane ampoule has the impermeable side **112** facing the human wrist **101**, and the permeable side **109** facing outward from the wrist. The armband is placed on the wrist **101** to enable the user to freely use their hands **107** and avoids having chemicals on their hands, which can interfere with tasks such as food preparation and fishing.

FIG. 6 is an exploded view of a catalytic heater combined with a membrane fuel and repellent ampoule and a decoy target. The vapor source fuel and chemical ampoule is shown as an assembly of a back impermeable layer **120** such as aluminum foil, a silicone rubber side wall **121** and a silicone rubber membrane **122** reinforced with a fiber glass **131**.

A fiberglass insulated panel or vacuum insulated panel **132** can be placed on the back impermeable wall **120** to block heat transfer. The assembly is glued together with silicone rubber along the perimeter **121**. Adjacent to the fuel ampoule is a

15

0.0625-inch thick sheet aluminum perforated box with 1 mm holes with 30% porosity **123**. Inside the perforated box are 1% Pt on alumina catalytic beads and platinum catalyst on rock wool **124**. The catalytic heater is described in more detail in co-pending patent application PCT/US02/32041, incorporated herein by reference in its entirety.

On top of the catalytic burner perforated box is a second scent ampoule **133** that diffuses scents that may tend to clog or break down in the catalytic heater. With this ampoule **133** they can be delivered independently from the fuel ampoule **121**, scents such as DEET, folic acid, octanol 4-methylphenol (a protein found in human sweat), pyrethrine (an insecticide). The scent ampoule **133** is made with an impermeable aluminum foil back layer **135**, a silicone rubber frame **134** and a permeable silicone rubber membrane **133**.

Surrounding or adjacent to the or the catalytic bed **123** is a porous woven or non-woven cloth cover **125** that has a pattern that has the features of a eye **128,127,126** and the surrounding tissue **125** as a visual target for the mosquitoes. This pattern can be embroidered onto the fabrics or can consist of layers of fabrics and possibly holes to reveal the scent ampoule **133** surface or the catalytic heater surface **123** that can be treated with a coating such as titanium dioxide or hydrophilic materials such as solid polymer electrolyte to emit an infrared spectrum similar to the surface of eyes or warm tissue.

In operation the fuel ampoule **121** is filled from a reservoir with a hose attached or the fuel ampoule, or is pre-filled with combustible fuels such as methanol, ethanol, diemethylether, formic acid or formaldehyde and scents in concentrations of approximately 1% such as DEET, lactic acid, octanol, 4-methylphenol (a protein found in human sweat), pyrethrine (an insecticide). Salts such as sodium sulfate decahydrate are added to the ampoule to act as a temperature control, and sodium sulfate is added to act as a water absorbent **131**. The fuels **131** such as methanol diffuse through the membrane **122** and catalytically combust in the catalytic bed **123** with the oxygen diffusing through the outer cover from the air **125**. The catalytic heater **123,121** limits its temperature to around 36° C. by reducing the fuel input when the sodium sulfate decahydrate in the fuel ampoule **121** releases water, absorbing heat, reducing the vapor pressure of the fuel diffusion and diffusing some water to the catalyst **124** which reduces the catalytic combustion.

The cloth reinforcing **129, 130** of the silicone membrane can also serve as a wicking material on the inside of the fuel ampoule to maintain liquid contact on the diffusion membrane and thereby maintain a steady delivery of chemicals through the membrane, even though the ampoule is gradually emptying and may be filled with gas. Other materials such as diatomaceous earth or fumed silica can be added to the fuel and salt hydrate mixture **131** to maintain contact with the membrane as well as to keep the salt hydrate suspended and avoid a settling out behavior that can occur because of its higher density from the fuel and salt crystals and change in dimensions from hydration to dehydration.

Scents in the fuel **131** diffuse through the membrane **122**, diffuse through the catalytic bed **123** and out through the surface of the cloth **125**. The scents attract and can block the odor receptors of insects. The catalytic heater **123** generates carbon dioxide and water attracting insects. The warm temperature of the heater **123** coupled with the coatings and color patterns **128,127,126** provide an attractive infrared and visible target for insects. This device can be used as an insect attractor, insect sensor blocker and disabler and as an insect decoy. It can be part of a stationary device or a mobile device or worn as part of apparel on humans and animals.

16

In FIG. 7A a cross-sectional view of a high voltage electrical discharge mosquito trap with catalytic heater, thermopile, fuel cell, or photovoltaic cells is shown. The central attraction target is a heated infrared and scent emitting spot **235**. In this trap the attraction surface **235** is on the bottom of the system. This example of the mosquito trap uses a catalytic heater and photovoltaic cells **220** and/or batteries **223** as a heat and electrical power source. The electric power from the photovoltaic array source **220** is used to energize the high voltage grid **234**.

Mosquitoes are attracted to the heated target and electrocuted by an electrical discharge as they pass between the guard screen **247** high voltage wires **234** and the target **235**. The bodies of the mosquitoes then fall down to the ground beneath the trap.

An alternative insect killing mechanism is to use an intense laser, flash lamp or light emitting diode **246** (shown in FIG. 7B) at the entrance **233** of the trap with optical arrangements to blind and or kill insect that are detected entering the trap, possibly through the capacitance change detected by the controlling electronics **224** on the high voltage grid **234** when an insect enters the trap. To conserve energy the high voltage grid **234** could be energized only when an insect enters the trap.

It should also be mentioned that the ampoule **227, 230** could be used to emit a chemical such as acetic acid that reacts with sodium bicarbonate to produce carbon dioxide, thus catalytic combustion is not necessary to produce carbon dioxide. Also to make heat, the ampoule **227** could deliver controlled release of a chemical that acts as a catalyst for another reaction such as water for a corrosion reaction of iron to iron oxide, and by temperature controlling this catalytic chemical delivery, the temperature regulation of the system can be achieved.

Behind the target surface **235** is the catalytic heater filled with a bed of alumina beads **231** coated with 1% platinum (Englehard) and alumina silicate fibers **232** coated with platinum (Infragas). Enclosing the bed of catalysts **231, 232** is an aluminum cylinder **235** perforated on either side of the catalysts. Above the catalytic heater **231, 232, 235** is the fuel ampoule **230, 227**. This is shown as single bladder filled with methanol, octanol, DEET **228**, fumed silica, and Sodium sulfate hydrate **229**.

The fuel ampoule **227** could be designed in many forms from insertable ampoules to capillary tubes that are filled from a larger pressurized reservoir **250** through an electronically controlled valve **245**. The outer surface **235** of the perforated aluminum cylinder **226** is coated with a red coating to match the infrared and visual electromagnetic emission of shallow surface blood vessels of skin and eyelids. The heater catalytically combusts the methanol as it diffuses through the ampoule membranes **230** to the catalytic sites **231, 232** with oxygen, which is diffusing, from the air under the heater.

Above the fuel ampoule there is an impermeable upper wall of the catalytic heater cylinder **226**. A direct DC to DC or DC to AC low voltage to high voltage converter **224** is connected to a battery **223**, which is charged with the photovoltaic array **220**. High voltage is delivered from the high voltage converter **224** to the electrocution grid **234** next to the heated target **235** through an insulated wire **225**. A diode **244** is placed in the circuit **236, 221** with the photovoltaic array **220** to avoid reverse current flow at night through the photovoltaic array **220**.

It should be mentioned that utility generated electricity or other sources of electricity can be used when available. More sophisticated electrical circuits can be used to control the energizing of the high voltage grid, and to control the fueling

through an electrically controlled valve **245** delivering fuel from a reservoir to the ampoule. This could allow the trap to sense and operate the trap only when mosquitoes are present and are hunting, such as by using the photovoltaic array **220** output to sense sunlight and to set a timer for dusk and dawn operation.

A temperature sensor could be incorporated into the controlling electronics **224** to open the valve **245** and energize the high voltage grid **234** only within the feeding temperature range of mosquitoes. The electronics **224** could sense air temperature, light conditions, and wind speed, such as by an inertial sensor observing wind buffeting, and use a microchip programmed to optimize the efficiency of the trap operation. Attraction lights, vibrators, and sound devices, or even devices to indicate the trap's effectiveness or need of servicing could be incorporated.

Physically holding the photovoltaic array **220** and housing the electronics **224**, the fuel ampoule **227**, and the catalytic heater **235** is in cone and tube shaped housing **222**. The housing **222** could be mounted on a post or hung from tree limbs.

In FIG. 7B the underside target and electrocution area of the mosquito trap is shown. The simulated eye target **235** consists of the central black infrared emission spot **242** that could have a coating or be made of a material that retains water such as sodium chloride, sugar, or solid polymer electrolyte (Nafion). The eye spot/cone is painted with titanium dioxide paint onto an aluminum or stainless steel metal cylinder that holds the catalytic burner **241**. The perforations **241** of the catalytic burner are shown. Surrounding the black eye spot **242** is the simulated iris **240** and conjunctiva "white" of the eye formed by painting the edge of black spot with a yellow or white paint, then a border of red or pink **239** and then the tan or light colored housing **238**. Over color coatings **242**, **240**, **239** and patterns a material that retains water or has an infrared emission similar to water, such as titanium dioxide paint or the perfluorosulfonic acid (Nafion®) or Sulfinated Butyl Rubber and polystyrene (DAIS-Analytic) is painted on.

Across the entrance to the housing tube **238** and the central spot are the guard screen **248** and the high voltage wires **237**. The high voltage is generated from the electrical high voltage power source. The guard screen can be placed around the entire trap or around the entrance to the bottom of the trap entrance to prevent accidental contact from humans and animals or large insects with the high voltage grid **248** in the trap.

A schematic illustration of a flash lamp, laser or light emitting diode **246** is shown on the side of the trap. An alternative to killing the mosquitoes by electrocution may be to blind the mosquitoes with a bright flash of light. It may also be possible to choose a light flash source that matches the maximum light wavelength sensitivity of the mosquitoes, such as the water infrared band 3-micron wavelength, to maximize the blinding effect on the mosquitoes, while being undetectable by humans. The underside of the photovoltaic **243** array is shown along with the cross-sectional line.

In FIG. 7C the exterior view of a high voltage electrical discharge mosquito trap with catalytic heater, thermopile, fuel cell, or photovoltaic cells is shown. The catalytic heater and high voltage trap portion **262** are shown as a cylinder with a conical roof **261** to protect the trap from rain falling into the trap **262** and the collection jar **265**. The photovoltaic array **268** is placed on the conical roof **261**. The hanging hook **260** can have a threaded connection to the conical roof **261** and a locking nut to allow the photovoltaic array to be oriented in the general direction of the sun. The hanging hook **260** can be placed on tree limbs, bars, posts, ropes or the eaves of build-

ings. Ideally the trap is placed high enough to avoid animal and children interference and in the general area of mosquitoes residence.

Placed in the sides of the trap **262** are three sound transducers **263** or microphones (two are shown). These sound transducers and/or microphones **263** can be used to detect the sound of the female mosquitoes, approximately 500 Hertz and, produce a 500 Hertz sound at about 30 dB to act as a attractive sound such as other female mosquitoes **267** feeding.

Around the base of the high voltage trap is a ring of stiff steel wires **264** to act as a guard ring to prevent humans and animals from reaching the high voltages grids in the trap. Attached to the bottom of the guard ring is a threaded ring **270** and a clear plastic or glass collection jar threaded on **265**. The collection jar **265** has a small water vent **269** in the bottom of the jar to drain away any liquid water that might fall into the collection jar. The bodies of the electrocuted mosquitoes **266** fall down from the trap **262** into the collection jar. In operation the trap is in a location where there is sufficient light to energize the photovoltaic array **268** and charge the batteries in the trap.

The trap is activated when the feeding conditions for mosquitoes **267** are electronically determined with the sensors in the trap and the photovoltaic array **268** with are met: such as temperatures above 7° C., wind speed below 6 meters/sec, 4 hours around dawn and 4 hours around dusk. The acceptable environmental conditions may be set to match the feeding behavior of the arthropods to be captured. The heater is turned on, and carbon dioxide, water vapor, and chemical scents are emitted by the trap. To conserve power the trap **262** can activate the high voltage by the sound of the mosquitoes **267** approaching the trap.

The mosquitoes will fly through the grid ring **264** and up into the trap attracted by the sound of other female mosquitoes and the chemical scents and the visual and thermal target of the trap **262**. When the mosquitoes approach the target up inside the trap **262** they will be electrocuted by an electrical discharge from the trap. Their bodies **266** will then fall down into the collection jar **265**.

In FIG. 8 the possible locations of membrane catalytic heaters and/or insect repulsion devices are shown located on human apparel. Heaters can be located in inside the pocket **147** area of a vest or jacket **145**. This allows the user to be able to heat their hands **149** when needed. The pocket heater **146** can emit DEET vapors. Catalytic heaters **146** can be located in a pocket in the lower and upper back area of the vest or jacket.

These heaters can be used to keep the wearer warm and emit DEET vapors and also pleasing scents. Ampoules and decoy images that are not catalytic could also be located at these locations to use body heat to emit chemical vapors and distract and impair insects. Wristband **148**, armband **150**, shoulder patches **165**, neck bands **144**, eyewear **143**, hat, **140**, neck cape **142**, and headband **141** heated or unheated ampoules and/or insect ampoules are shown. The heaters with or without scents can be used just to heat portions of the human body for comfort or therapy. The temperature regulating features of the ampoules combined with the catalytic heaters are important in delivering a safe and acceptable heat delivery to the human.

Other mechanisms that could be incorporated with the heaters are vibrating and periodic constriction devices, such as in the arm band **150**, that could be used to massage and induce circulation in humans. They can also make the decoy more attractive to arthropods that can detect periodic motion.

Periodic cycling with on-off cycles to deliver a cycling temperature to the skin can also be therapeutically useful to increase blood circulation.

In FIG. 9 the possible locations of membrane catalytic heaters and/or insect repulsion devices are shown located on the backside of human apparel. Heaters can be located in inside the upper **156** and lower portions **158** of a vest or jacket **159** inside pockets or attached to the outside of the apparel with Velcro or adhesives. Heat distribution can be done by forming the fuel ampoule covering a larger area that has the catalytic heater and with impermeable perimeter or liquid filled sealed ampoules or heat pipes.

Also shown are the heater, decoy, or insect repulsion devices located on the eyeglass strap **153**, shirt collar **155** or hatband **152**. The catalytic heaters can be located in a pocket in lower back **158**, upper back area **156**, collar **155**, arm band **157**, and head band **152** to keep the wearer warm and emit DEET vapors and also pleasing scents. A hat skirt **154** can be used just to protect portions of the head and neck and cover as much of the exposed skin as possible.

Thermal insulation such as Thinsulate® (3M Corporate Headquarters, 3M Center, St. Paul, Minn. 55144-1000) or vacuum insulation panels could be located between the heater and the person when it is not desirable to heat the human while still running the catalytic heater to repel or distract insects. One possible arrangement is to have an inside and outside pocket **158**, **156** that permits the user to place the catalytic heater inside or outside the insulation of the jacket or hat.

Ampoules and decoy images that are not catalytic could also be located at these locations to use body heat to emit chemical vapors and distract and impair insects. The heaters with or without scents can be used just to heat portions of the human body for comfort or therapy. The temperature regulating features of the ampoules combined with the catalytic heaters are important in delivering a safe and acceptable heat delivery to the human.

Other mechanisms that could be incorporated with the heaters such as in the arm band **157** and lower and upper back panels **156,158** are vibrating and periodic construction devices that could be used to massage and induce circulation in humans. The heating of the skin under the heater or by self-heating due to the thermal insulation of the ampoule can be used to dilate the skin pores and deliver chemicals through the skin from a diffusion ampoule in contact with the skin. The eyeglasses strap **153** can be formed as a hollow tube of nylon fabric with a sealed silicone rubber tube ampoule filled with DEET, sodium sulfate, and other emission chemicals inside. The sodium sulfate additive can act as a dehydrating mechanism to keep the vapor pressure of the DEET high at temperatures below 32 C.

Above 32 C the dehydration of the water from the sodium sulfate will act to reduce the vapor pressure of the DEET and interfere with the diffusion of DEET toward the diffusion membrane. Thus, the sodium sulfate additive works to stabilize the temperature sensitivity of the delivery of DEET. The outer fabric surface is coated with a titanium dioxide striped pattern of black, white and tan bands to act as and attractive image decoy for the insects.

In FIG. 10A the hat with an insect repellent ampoule inserted into a band around the perimeter of the hat is shown. The hat **170** and hatband **171** are made from cotton fabric and dyed or painted with a titanium dioxide painted color pattern or materials with a high infrared emissivity. The color pattern shown in the close-up view consists of bands of black **175**, yellow or white **174**, **176** and red or pink **173**, **177**. The remainder of the hat **178**, **170** consists of light colors of tan

and can be dyed or painted with materials with a low infrared emissivity. The hatband **172** is heated though catalytic heating or heat transfers from the wearer to deliver scents such as DEET and make a thermally attractive target for insects.

In FIG. 10B a catalytic heater located in a pocket on a glove is shown. In this figure the pocket **181** is located on the backside of the glove. A circular pattern **182**, **183**, **184** either formed by painting, dying or forming a hole to reveal the surface of the chemical ampoule is shown. The pattern consists of a black central spot **182**, a yellow perimeter **183**, and a red or pink outer perimeter **184**. The glove **180** is tan or a low emissivity and dry surface and made of a hydrophobic material such as GoreTex® (W.L. Gore & Associates, Inc., 555 Papermill Road, Newark, Del. 19711). The circular patterned surface **182**, **183**, **184** incorporates or is formed from a material that has an emissivity of thin skinned blood containing tissue. The heat from the catalytic heater can be used to warm the hand in the glove **180**, or the heater can be located outside the insulation of the glove to act as heated attractive decoy for mosquitoes.

In FIG. 11 the possible locations of membrane catalytic heaters and/or insect repulsion devices are shown located on a boot **206** or on the sock ankle area **196** of a human. A catalytic heater is formed to fit the curved shape of the boot. A heat pipe **207** is part of the lower edges of the heater and goes around the toe area of the boot to transfer heat into the toe area. This heater consists of a perforated sheet metal brass box **202** filled with 1% platinum by weight on alumina beads and Infragas catalyst coated rock wool. The fuel ampoules **198** are made of pine or other porous woods soaked in methanol and scent chemicals and salts. The wooden ampoule **198** is inserted into the perforated metal **201** slot **200** located inside the perforated metal box **202** filled with catalysts. A brass cover door **197** is used to cover the slot ampoule. The side of the heater toward the boot **206** is painted black to radiate thermal energy to the boot. The outer surface of the heater can have a cloth covering of high temperature fabric such as PBI non-woven, and a pattern **205**, **204**, **203** that is attractive to insects and acts as thermal insulation to retain heat around the boot and heater.

On the ankle region of the leg **190**, **196** a sock or ankle band **195** with a pouch **191** for the permeable ampoule filled with the insect attracting and sensor interference chemicals is located. The outer surface of the sock **195** can have patterns and colors that attract insects consisting of a black spot **194**, a white or yellow perimeter **193** and a red or pink perimeter **192**. Outside of the color patterns the remainder of the ankle or sock **195** is coated, formed, or colored with a material with a low thermal emissivity such as a light tan **199** GoreTex®. These attraction patterns **194**, **193**, **192** can be formed or coated with a substance such as titanium dioxide or with a material that emits infrared light similar to soft tissue of an animal. The catalytic heaters, insect attraction repulsion devices, or chemical delivery ampoules can also be placed in helmets, glasses frames, goggles, glasses straps, belts, pants, dresses, capes, rain coats and sleeping bags.

List of Components in Figures

FIG. 1. Eye image cloth wristband with a dual insertable repellent scent ampoule.

1. Cloth wrist, ankle, neck, head or hat band with interior pocket.
2. Grey, white, silver, or tan, (light colored) cloth.
3. Red, magenta or pink colored cloth.
4. White or yellow colored.
5. Black colored cloth.

6. Slit opening into the interior of the cloth band pocket.
7. DEET and scents filled silicone rubber ampoule outer membrane.
8. Second silicone rubber membrane and ampoule for the more volatile fluids.
9. Interior side wall silicone membrane.
10. DEET fluid inside the ampoule.
11. Perimeter spacer material or inner porous material.
12. Stabilizing chemical crystals and wicking material.
13. Aluminum foil sheet.
14. Stabilizing chemical and wicking material.
28. Second more volatile fluids of acetone, methanol, ethanol, and folic acid.
- FIG. 2. Chemical diffusion ampoule and sealed packet.
15. Heat-sealed perimeter of the impermeable ampoule pouch.
16. Impermeable outer ampoule pouch.
17. Permeable seal of the silicone rubber or urethane rubber pouch.
18. Selectively permeable ampoule.
19. DEET in ampoule and suspension matrix or material.
20. Slit apart other half of outer impermeable ampoule.
21. Pouch opening in outer impermeable pouch slit open.
22. Pouch opening in outer impermeable pouch slit open.
23. Inner porous material and spacer.
24. Impermeable back membrane.
25. Chemical crystals such as Sodium sulfate hydrate.
26. Aluminum foil back.
280. Outer membrane.
281. Frame material.
282. Hydrate salt.
283. DEET and scent fluids.
284. Back impermeable membrane.
285. Back wall.
- FIG. 3A Fan driven mosquito trap system top view of heated spot.
30. Black central heated disk.
31. White or yellow perimeter disk.
32. Red or pink sides on throat of flow channel.
33. Outer flow channel and case tan, white or brown (light colored).
67. Carbon dioxide and scent vent.
68. Fresh air intake channel to fuel cell.
- FIG. 3B Fan driven mosquito trap system side view cross-section.
34. Central black heated disk.
35. White or yellow perimeter on disk.
36. Methanol fuel.
37. Chemical hydrate such as sodium sulfate hydrate.
38. Selectively permeable membrane.
39. Catalytic beads and fibers.
40. Negative electrodes from fuel cell to fan.
41. Cathode on fuel cell array, could also be a thermopile.
42. Electrolyte on fuel cell array element.
43. Anode on fuel cell array.
44. Recirculated air flow.
45. Outer air flow from fan.
46. Air flow from fan.
47. Fan motor.
48. Fan blades.
49. Insect filter mesh.
50. Trapped insects.
51. Air filter mesh to fuel.
52. Air flow from fan.
53. Air flow from intake.
54. Perforation to let air into catalytic heater.
55. Positive electrode from fuel cell output.

56. Recirculated airflow.
57. Flying insects.
58. Electrical via contact in fuel cell array.
59. Fuel cell air manifold.
- 5 60. Alumina silicate fibers coated with platinum.
61. Cotton fibers or suspension matrix.
62. Entrance of trap.
63. Air flow from intake.
64. Fresh air inflow to fuel cell and air intake channel.
- 10 65. Carbon dioxide and scent vent flow.
66. Carbon dioxide and scent vent hole.
- FIG. 4A Rotating helical mesh trap top view of heated spot.
70. Black spot heated fuel tank.
71. Gap between the stationary target and the rotating helix.
72. Screen mesh helix.
73. Center support and view shield.
74. Leading edge of the rotating mesh helix colored pink or red.
75. Outer hub of rotating helix.
- 20 76. Air gap between rotating helix hub and outer case.
77. Outer case, tan colored.
- FIG. 4B Rotating helical mesh trap side cross-sectional view.
78. Center support.
- 25 79. Selectively permeable fuel ampoule.
80. Methanol fuel.
81. Hydrated salt such as sodium sulfate hydrate.
82. Catalyst beads on alumina supports.
83. Screen mesh helix.
- 30 84. Pores in catalytic heater tube.
85. Positive anode of the fuel cell array element.
86. Porous electrolyte.
87. Air cathode electrode of the fuel cell array element.
88. Air vents for air supply to fuel cell cathodes.
89. Exterior or helix hub.
90. Small pores to allow some air flow out of the mosquito trap.
91. Electric motor.
92. Positive electrode wiring from fuel cell to motor.
93. Negative electrode wiring from fuel cell to motor.
94. Via interconnect on fuel cell array.
95. Cathode electrode on fuel cell array.
96. Outer case (tan colored).
97. Insect wiper crusher.
- 45 98. Permeable central spot.
99. Exit aperture.
- FIG. 5 Wrist band shown on human wrist and diffusion ampoule.
101. Human arm.
- 50 102. Red or pink colored area of wrist band.
103. Yellow or white colored area of wristband.
104. Black colored area of wristband.
105. Chemical emitting area where ampoule is placed inside wristband.
- 55 106. Cloth wrist band with interior pocket or void.
107. Human hand.
108. Chemical emitting ampoule.
109. Membrane permeable to chemicals.
110. Sealed perimeter of ampoule.
- 60 111. Chemical in ampoule.
112. Back wall of ampoule impermeable to emitting chemicals.
113. Outer ampoule permeable membrane sealed to the impermeable membrane.
- 65 FIG. 6 Membrane catalytic heater attractor exploded view.
120. Impermeable back wall material.
121. Frame material.

122. Methanol permeable membrane.
 123. Perforated aluminum metal box filled with catalytic felt and beads.
 124. Ventilation holes in perforated metal box with catalyst inside.
 125. Tan or brown colored fabric.
 126. Red or pink colored fabric.
 127. Yellow or white colored fabric.
 128. Black spot on fabric.
 129. Wicking cloth.
 130. Fiber cloth ends.
 131. Fuel and chemicals inside such as: methanol, lactic acid, octonol, DEET, and sodium sulfate hydrate.
 132. Insulated back wall.
 133. Outer permeable membrane of the scent ampoule.
 134. Frame of the scent ampoule.
 135. Back impermeable wall of the scent ampoule.
 FIG. 7A Cross-sectional view of a high voltage electrical discharge mosquito trap with catalytic heater, with photovoltaic cell electrical power source.
 220. Photovoltaic cell.
 221. Electrical output from solar cell.
 222. Cone on top of case.
 223. Battery.
 224. DC low voltage to high voltage DC or AC voltage converter and control system.
 225. High voltage wire.
 226. Heater box case.
 227. Fuel and scent ampoule.
 228. Liquid fuel; methanol, scents and salts.
 229. Sodium sulfate hydrated with water.
 230. Permeable membrane.
 231. Alumina beads coated with platinum catalyst.
 232. Alumina silicate fibers coated with platinum catalysts.
 233. Dielectric outer tan colored case.
 234. High voltage grid wires.
 235. Porous catalytic burner box.
 236. Grounded wire connection from battery to DC converter and photovoltaic cells.
 244. Diode.
 245. Electronically controlled valve.
 246. Laser, flashlamp, or light emitting diode.
 247. Guard screen.
 248. Guard screen.
 250. Pressurized reservoir.
 FIG. 7B Underside view of the electrocution insect trap with catalytic chemical vapor and heat source.
 237. High voltage wires.
 238. Outer tan case.
 239. Red colored titanium oxide coated surface of the heater.
 240. White or yellow color titanium oxide coated surface of heater.
 241. Holes in perforated metal of heater.
 242. Black central spot with a coating that simulates a moist eye.
 243. Under side view of photovoltaic cells.
 FIG. 7C Exterior view of the of the electrocution insect trap with photovoltaic array catalytic chemical vapor and heat source.
 260. Hanging hook.
 261. Conical shaped roof cover.
 262. The mosquito trap and scent emitters.
 263. Sound emitters and detectors.
 264. Guard wires.
 265. Clear plastic or glass collection jars.
 266. Dead mosquitos collected at the bottom of the trap.
 267. Mosquitos attracted to the trap.

268. Photovoltaic array.
 269. Water drain hole at the bottom the collection jar.
 FIG. 8 Front view of upper body of possible locations of heaters, insect repellent, insect confusion, or insect attraction devices incorporated into apparel.
 140. Hat.
 141. Hat band.
 142. Hat skirt cloth
 143. Glasses or goggles.
 144. Neck band repellent.
 145. Shirt or jacket.
 146. Body heaters in jacket.
 147. Pocket.
 148. Wrist band.
 149. Hand.
 150. Arm band.
 165. Shoulder attractant and repellent.
 FIG. 9. Back view of upper body of possible locations of heaters, insect repellent, insect confusion, or insect attraction devices incorporated into apparel.
 151. Hat.
 152. Hatband.
 153. Glasses or goggles strap.
 154. Neck hat skirt.
 155. Collar heater or band.
 156. Upper back heater.
 157. Shirt or jacket.
 158. Lower back heater.
 159. Jacket.
 FIG. 10A. Hat with insect repellent, insect confusion, or insect attraction band and enlarged view of band color patterns.
 170. Hat.
 171. Hat band.
 172. Ampoule inside band.
 173. Red or pink dyed band.
 174. Yellow or white dyed band.
 175. Black dyed band.
 176. Yellow or white dyed band.
 177. Red or pink dyed band.
 178. Tan dyed fabric of hat.
 FIG. 10B. Glove with insect repellent, and or heater.
 180. Tan colored glove.
 181. Ampoule and or heater inside glove pocket.
 182. Black dyed cloth spot.
 183. Yellow, white or silver dyed cloth.
 184. Red or pink dyed cloth.
 FIG. 11 Placement of ankle insect repellent and shoe heater.
 190. Leg.
 191. Ampoule in ankle band or sock.
 192. Red or pink dyed area.
 193. Yellow, silver, or white area on band.
 194. Black dyed area on band.
 195. Tan dyed ankle band or sock.
 196. Leg and sock.
 197. Cover door on heater.
 198. Wooden ampoule filled with methanol fuel.
 199. Tan colored catalytic heater.
 200. Slot in heater box.
 201. Inner perforated metal apertures.
 202. Perforations in mesh containing catalysts.
 203. Red or Pink colored area.
 204. Yellow, silver, or white colored area.
 205. Black colored area.
 206. Boot.
 207. Heat pipe.

Company Names/Materials/Addresses

Specialty Silicone Fabricators Inc.
 3077 Rollie Gates Dr.
 Paso Robles, Calif. 93446
 Englehard
 Chemical Catalyst Group
 554 Englehard Dr.
 Seneca, S.C., 29678
 Infragas S. p. A.
 via Lavoresco
 10-10072 Caselle
 (TO) Italy
 DAIS-Analytic Corporation
 11552 Prosperous Dr.
 Odessa, Fla., 33556
 Perfluorosulfonic Acid, (Nafion®)
 DuPont Corporation.
 Alcohol solutions available through: Solutions Technology, Inc., P.O. Box 171, Mendenhall, Pa. 19357.
 Texollini
 2575 El Presidio St.
 Long Beach, Calif. 90810
 PEMEAS GmbH,
 Industriepark Höchst, G864
 65926 Frankfurt/Main, Germany
 Thinsulate®
 3M Corporate Headquarters
 3M Center
 St. Paul, Minn. 55144-1000
 GoreTex®
 W.L. Gore & Associates, Inc.
 555 Papermill Road
 Newark, Del. 19711
 Essential features include, but are not limited to, the following:

1. Chemicals that attract, repel, or interfere with insect or arthropods behavior delivered through a selectively permeable membrane, molecularly selective membrane or chemically permeable layer.
2. The selectively permeable membrane allows chemicals to be delivered and not back diluted by the product water.
3. Using different and multiple membrane ampoules to deliver chemicals.
4. A chemical additive to the mixture contained by the membrane that controls water content of the mixture to maintain delivery rates of diffusing chemicals over a range of temperatures and humidities.
5. Chemicals that attract, repel, or interfere with insect behavior are contained in a permeable membrane or material and also contain a fuel for a catalytic heater or fuel cell or combustion driven device.
6. Using patterns and colored surfaces and different infrared emitting surfaces to attract and channel insects toward traps or decoy surfaces.
7. Creating surfaces that simulate the prey of insects.
8. Using carbon dioxide emission to attract insects.
9. Using moisture emission to attract insects.
10. Using chemical emissions to attract insects.
11. Using black and red and yellow patterns to attract insects.
12. Using sound emissions to attract and startle and repel insects.
13. Using light to attract startles, or blind insects.
14. Using warm moist surfaces to attract insects.
15. To use a sequence of attraction, visual attraction, chemical sensor disabling, and startling to disable insects.

16. To use a sequence of attraction, chemical sensor disabling, and visual attraction and then trapping.
17. Packaging the systems as apparel.
18. Forming an impermeable barrier on the permeable ampoule to block diffusion of arthropod interference compounds from reaching the skin.
19. Packaging the heater system with insulation or super insulation on one side to insulate the person from the heater or insulate the person from the cold.
20. Packaging the system as a stand-alone appliance.
21. Packaging the system as part of an AC powered appliance.
22. Packaging the chemical ampoules in sealed outer ampoules to be opened when needed.
23. Using body heat, combustion heat, catalytic heaters, or fuel cells or thermal mass to enhance the diffusion rate delivery.
24. The material additive to the fuel can act as a fire retardant and extinguisher as it phase changes with heat and decomposes.
25. Suspension materials such as diatomaceous earth to keep the hydrate chemicals suspended.
26. The compound effect of the hydrates releasing water and the water affecting the catalysts or inhibiting reactions in the heaters acting to slow down the reactions that can be used to create an autothermostatic system.
27. The compound effect of the water released from the hydrate causing the membrane to change its permeability another compound changing form in the fuel such as hydrogel to block fuel diffusion. Water release can cause mechanical mechanisms to change form.
28. Using a rotating mesh or permeable helix to trap insects. While the invention has been described with reference to specific embodiments, modifications, and variations of the invention may be constructed without departing from the scope of the invention, which is defined in the drawings and the following claims.

I claim:

1. A wearable arthropod sting reduction apparatus comprising:
 - a chemical system comprising a gaseous molecular delivery system and a chemical or chemicals that attract, repel or interfere with insects behavior, further comprising a container having a permeable layer to contain and release chemical gaseous molecules of said chemicals that attract, or repel or interfere with insects behavior by diffusion through the permeable layer; said chemicals comprising a component that changes chemical state with temperature and acts to moderate the chemical gaseous molecules diffusion rate or vapor pressure;
 - a surface comprising indicia having a configuration colored and shaped to simulate an eye and eye perimeter tissue; and
 - wherein said chemical system is coupled to said surface such that diffusion of said chemical gaseous molecules through said permeable layer is associated with said indicia at a location that enables said indicia to further simulate infrared emissions of a warm blooded animal.
2. The apparatus of claim 1, wherein the permeable layer comprises a molecularly selectively permeable layer to contain and release chemical molecules by diffusion through the selectively permeable layer.
3. The apparatus of claim 1, further comprising three or more chemicals and an auto thermostatic system that uses the three or more chemicals wherein the chemicals interact with each other to modulate production of heat to maintain a temperature.

4. The apparatus of claim 1, wherein said chemicals comprise arthropod affecting chemicals; wherein said chemical system uses the permeable layer to contain and release the arthropod affecting chemicals by diffusion through the permeable layer.

5. The apparatus of claim 2, wherein said chemicals comprise arthropod affecting chemicals; wherein said chemical system uses the molecularly selectively permeable layer to contain and release the arthropod affecting chemicals by diffusion through the selectively permeable layer.

6. The apparatus of claim 4, further comprising a body contact, catalytic heater, or fuel cell heat source.

7. The apparatus of claim 1, wherein a release of arthropod affecting chemicals by diffusion through the membrane comprises releasing molecules that attract and then disable chemical sensors of insects and wherein the container has an impermeable layer on one side.

8. The apparatus of claim 4, wherein the container further comprises an impermeable membrane to contain the chemicals before use.

9. The apparatus of claim 5 wherein the container further the selectively permeable membrane and an impermeable membrane to contain the chemicals.

10. The apparatus of claim 1, wherein said surface has a source of electromagnetic emissions characteristic of eye and eye perimeter tissue of warm-blooded animals.

11. The apparatus of claim 10, further comprising an arthropod attractant or decoy that uses a distinct configuration resembling the eye with a dark feature with borders of red and yellow.

12. The apparatus of claim 1, further comprising a fuel cell and catalytic heater coupled together with a common fuel supply such that they regulate temperature of the component of the contained chemicals that change chemical state with temperature and acts to moderate the diffusion rate or vapor pressure of the chemical fluid.

13. The apparatus of claim 2 wherein the molecularly selectively permeable layer is molecularly selectively permeable with a high permeability to carbon dioxide, alcohols, and hydrocarbons, and low permeability to water.

14. The apparatus of claim 2 wherein the molecularly selectively permeable layer is molecularly selectively permeable with a high permeability to as N,N-diethyl-metatoluamide (DEET) and low permeability to water.

15. The apparatus of claim 1, wherein the permeable layer is silicone rubber.

16. The apparatus of claim 1, further comprising an energy conversion system and wherein the chemicals delivered through the membrane are used as reactants to energize the energy conversion system to generate heat with temperature regulation of the vapor pressure or diffusion control used to achieve thermostatic control.

17. The apparatus of claim 1 wherein the chemicals delivered through the permeable membrane are used as reactants in a heater to make heat, and the temperature regulation of the vapor pressure or diffusion is used to achieve thermostatic control.

18. The apparatus of claim 1 wherein the delivered chemicals are used as reactants in a heater to make heat and the temperature regulation of the vapor pressure or diffusion is used to achieve thermostatic control and an arthropod attractive target.

19. The apparatus of claim 1 wherein delivered chemicals are used as reactants in a heater to make heat and the temperature regulation of the vapor pressure or diffusion rate of

molecules is used to achieve thermostatic control, which can be used for therapeutic purposes in contact with humans or animals.

20. The apparatus of claim 1 wherein delivered chemicals are used as reactants in a heater to make heat and the temperature regulation of the vapor pressure or fluid diffusion is used to achieve thermostatic control.

21. The apparatus of claim 1 wherein diffusing chemicals are catalytically combusted with oxygen from the air.

22. The apparatus of claim 1 wherein delivered chemicals are used as reactants in a fuel cell to make heat, and temperature regulation of the vapor pressure or diffusion is used to achieve thermostatic control, which can be used for therapeutic purposes in contact with humans and animals.

23. The apparatus of claim 1 further comprising at least one of heater and fuel cell and wherein the at least one of heater and fuel cell receive a diffusing chemical of hydrogen, water, methanol, dimethyl ether, ethanol, formic acid, or formaldehyde, from the permeable layer and utilize oxygen from the air.

24. The apparatus of claim 4 further comprising a catalytic heater wherein the vapors or diffused molecules are used at least in part to generate heat, scents, and carbon dioxide, and to provide an attractive infrared target or to simulate a visual target.

25. The apparatus of claim 4 wherein the vapors or diffused molecules are used as part of an arthropod interference system in the form of an ampoule for attaching to a person or animal to generate scents and provide at least one of a distractive infrared target and visual target.

26. The apparatus of claim 4 wherein vapors or diffused molecules are used as part of an arthropod interference system in the form of an ampoule for attaching to a person or animal to generate scents, and heat and provide at least one of a distractive infrared target and visual target.

27. The apparatus of claim 4 wherein the vapors or diffused molecules are used as part of an arthropod interference system in the form of an ampoule for attaching to a person or animal to generate scents and heat and provide at least one of a distractive infrared target and visual target, and a diffusion barrier is placed such as to be between a human and the ampoule during use.

28. The apparatus of claim 4 wherein the vapors or diffused molecules are hydrogen, water, methanol, dimethyl ether, ethanol, formic acid, or formaldehyde, N,N-diethyl-3-methylbenzamide (DEET), or octanol, used as part of an arthropod interference system in the form of an ampoule with the permeable layer facing out into the air and an low permeable layer that would be facing toward a person or animal during use, and to generate scents and form at least one of a distractive infrared target and visual target with patterns to simulate the eyes of animals with exposure to the membrane.

29. The apparatus of claim 4 wherein the vapors or diffused molecules are hydrogen, water, methanol, dimethyl ether, ethanol, formic acid, or formaldehyde, N,N-diethyl-3-methylbenzamide (DEET), dimethyl disulfide or octanol, used as part of an arthropod interference system in the form of an ampoule with the permeable layer facing out into the air and an low permeable layer that would be facing toward a person or animal during use, and to generate scents and heat with a catalytic heater with platinum dispersed on alumina beads and alumina silicate fibers, and form at least one of a distractive infrared target and visual target with patterns to simulate the eyes and perimeter of eyes of animals with exposure to the membrane.

30. The apparatus of claim 4 wherein diffused molecules are methanol, dimethyl ether, ethanol, formic acid, acetone,

29

or formaldehyde, N,N-diethyl-3-methylbenzamide (DEET), folio acid, lactic acid, citronella, perfumes, sugars, 4-methylphenol, pyrethrum, or octanol contained by the permeable membrane, a water absorbing chemical of sodium sulfate is contained by the membrane, is used as part of an arthropod interference system in the form of permeable membrane or membranes diffusing into a catalytic heater with platinum dispersed on alumina beads and alumina silicate fibers, with air diffusing into the catalytic heater, products of carbon dioxide and water diffusing out of the catalytic heater, forming an attractive infrared target with titanium dioxide, perfluorosulfonic acid or sulfinated butyl rubber and polystyrene coatings visual target with patterns to simulate the eyes and perimeter of eyes of animals.

31. The apparatus of claim 1 wherein a layer of low permeability to the chemicals are formed on one side of the container.

32. The apparatus of claim 2 further comprising a chemical reaction, catalytic heater or fuel cell that uses the molecules of the chemical or chemicals to run the chemical reaction, catalytic heater or fuel cell.

33. The apparatus of claim 2 wherein the chemicals or molecules of the chemicals repel insects.

34. The apparatus of claim 2 wherein the chemicals create carbon dioxide.

35. The apparatus of claim 2 wherein the chemicals are fuel to create carbon dioxide through catalytic combustion to attract insects.

36. The apparatus of claim 2, wherein the chemicals are a fuel to create carbon dioxide through catalytic combustion, or electrochemistry, or interaction with another chemical.

37. The apparatus of claim 1, wherein the chemicals are to create carbon dioxide attractant through the interaction of acetic acid or formic acid diffused through the membrane and interacting with sodium bicarbonate or calcium carbonate.

38. The apparatus of claim 2, wherein diffusion of the molecules of the chemical or chemicals through the permeable membrane attracts insects.

39. The apparatus of claim 2, wherein diffusion of the molecules of the chemical or chemicals through the permeable membrane first attracts arthropods and then blocks their chemical sensors.

40. The apparatus of claim 2, wherein diffusion of the molecules of the chemical or chemicals through the permeable membrane attracts arthropods, block their chemical sensors, and repels the arthropods.

41. The apparatus of claim 2, wherein diffusion of the chemical or chemicals through the permeable membrane attracts arthropods, block their chemical sensors, and repels the arthropods.

30

42. The apparatus of claim 2, wherein molecular diffusion of the chemical or chemicals through the permeable membrane attracts arthropods, block their chemical sensors, and then attracts the insects to decoy targets through light or sound.

43. The apparatus of claim 2, wherein molecular diffusion of a chemical or chemicals through the permeable membrane attracts, blocks arthropod chemical sensors, and repels arthropods through light or sound.

44. The apparatus of claim 2 wherein the indicia is comprised of a surface coating simulated visual target that simulates the infrared emission of the animal eye, and skin.

45. The apparatus of claim 2 wherein the indicia is comprised of a surface coating of solid polymer electrolytes, water, saline solution, or titanium dioxide simulates the infrared emission of the animal eye and skin.

46. The apparatus of claim 2, wherein an exposed surface of the permeable membrane simulates the infrared emission of the animal eye, and skin.

47. The apparatus of claim 2 wherein a cover of the permeable layer is a wicking surface that wicks sweat and accumulates chemicals contained in sweat.

48. The apparatus of claim 2, wherein the indicia is comprised of an arthropod attractant, or decoy having a distinct spatially defined infrared emitting spot for attracting arthropods.

49. The apparatus of claim 2, wherein the indicia is comprised of

an arthropod attractant, or decoy having a distinct defined emitting spot that is warmed above the surroundings and emits attractive chemical to the arthropods, and chemical sensor disabling chemicals.

50. The apparatus of claim 2, further comprising an arthropod attractant, decoy or repulsion device powered by the chemicals released through the layer.

51. The apparatus of claim 2, further comprising an arthropod or insect attractant, decoy or repulsion device wherein the chemicals are contained in an ampoule made of wood.

52. The apparatus of claim 44, further comprising an arthropod attraction system and a catalytic heater or fuel cell to generate heat to keep the simulated visual target at an attractive temperature to insects, also generating carbon dioxide and scents.

53. The apparatus of claim 2, further comprising an arthropod attraction system, a catalytic heater to generate heat, scents, and carbon dioxide and to provide an attractive infrared target, photovoltaic cells and an electrical energy storage to simulate a visual target.

* * * * *